



WORLD RAFTING FEDERATION
RAFTING AND PARA-RAFTING SPORT
RULES

TABLE OF CONTENTS

Section I - General Rules

Art. 1 – Federal competitive activities	6
Art. 2 – Fight against doping.....	6
Art. 3 – Classification of competitions	6
Art. 4 – Sport calendar and competition rules.....	7
Art. 5 – Participation in competitions.....	7
Art. 6 – Awards.....	7
Art. 7 – WRF Ranking.....	7

Section II – The Parties

Art. 8 – Participation	8
Art. 9 – Technical clothing and individual safety equipment.....	9
Art. 10 – The Chief Judge	10
Art. 11 – The Judges.....	11
Art. 12 – The Local Organizing Committee.....	11
Art. 13 – Tasks of the Local Organizing Committee	12
Art. 14 – Race Secretariat: establishment and tasks.....	13
Art. 15 – Race Director	14
Art. 16 – The Safety Manager	14
Art. 17 – Rescue Service.....	15
Art. 18 – Timing Service.....	15
Art. 19 – The Head of Delegation.....	15

Section III – Organisational Rules

Art. 20 – The bulletin.....	16
Art. 21 – The schedule	16
Art. 22 – Registration and entry fees.....	17

Art. 23 – Participation.....	17
Art. 24 – Movement and cancellation of a race.....	17
Art. 25 – Accreditation of Delegations and Head of Delegations’s meeting	17
Art. 26 – Withdrawals.....	18
Art. 27 – Race bibs	18
Art. 28 – Starting list.....	18
Art. 29 – Publication of the results	18
Art. 30 – Advertising on the venue.....	19
Art. 31 – Advertising on the technical materials	19

Section IV – Technical Rules

Art. 32 – Course features.....	19
Art. 33 – Rafts features.....	20
Art. 34 – Starting provisions.....	21
Art. 35 – Conducts during the course.....	22
Art. 36 – Loss or damage of the paddle	24
Art. 37 – Flipping of the boat.....	24
Art. 38 – Race Suspension.....	24
Art. 39 – Measures of disqualifications	24
Art. 40 – Complaints	25

Section V – Particular requirements for RX races

Art. 41 – Definition.....	25
Art. 42 – Timed sprint.....	26
Art. 43 – Timed sprint’s start	26
Art. 44 - Timed sprint’s arrival.....	26
Art. 45 – Timed sprint’s rankings.....	26
Art. 46 – Knockout phase	27
Art. 47 – Course	27
Art. 48 – Gates.....	28
Art. 49 – Penalty	28

Art. 50 – Elimination	29
Art. 51 – Disqualification.....	29
Art. 52 – Start of the knockout phase.....	29
Art. 53 – Arrival of the knockout phase	29
Art. 54 – Rankings.....	30

Section VI – Particular requirements for the Slalom races

Art. 55 – Definition.....	30
Art. 56 – The course.....	30
Art. 57 – Starting Orders	31
Art. 58 – Route Approval.....	31
Art. 59 – Start.....	31
Art. 60 – Gates.....	31
Art. 61 – Passing the gates.....	32
Art. 62 – Penalty	33
Art. 63 – The Gate Judges	34
Art. 64 – Signals for Gate Judges.....	34
Art. 65 – Arrival	35
Art. 66 – Ranking.....	35
Art. 67 – Obstacle on the course.....	35

Section VII – Particular requirements for the Downriver races

Art. 68 – Definition.....	35
Art. 69 – Distances.....	35
Art. 70 – Start.....	36
Art. 71 – Arrival	36
Art. 72 – Rankings.....	36
Annex A.....	37
Annex B.....	38
Annex C	39
Annex D.....	43

Section I – General Rules

Art. 1 – Federal competitive activities

1. The activity of the World Rafting Federation is constituted by the Rafting competitions held or recognized by the World Rafting Federation, hereinafter referred as WRF.
2. The WRF events are classified as:
 - a. RX (maximum distance 600m);
 - b. Slalom (maximum distance 600m);
 - c. Down River (minimum distance 3,000m).
3. The present Sport Rules applies also to Para-Rafting activity; specific dispositions are set out in the Annex A.

Art. 2 – Fight against doping

1. Doping is strictly prohibited and appropriate health checks on the athletes may be performed according to what is established by WRF, by IOC and WADA.
2. The lists of doping substances categories and doping methods correspond to those approved by the IOC and WADA.
3. Random checks may be performed both by the WADA and the WRF.

Art. 3 – Classification of competitions

1. The WRF competitions are classified in:
 - Class A) World Championships, World Cups;
 - Class B) Continental Championships and Continental Cups;
 - Class C) International events recognized by the WRF;
 - Class D) National Championships
2. Competitions referred to in Art. 3.1, Class A), B) and C) are sanctioned by the WRF Executive Board.
3. National Championships are sanctioned by the respective WRF National Member that shall communicate the dates to the WRF Secretary. International Teams can take part in National Championships if established in the National Bulletin.
4. Other promotional events must be approved by the competent WRF bodies, even if they do not constitute, for any reason, a WRF competitive activity.
5. Races can be held both on natural and artificial courses, provided that these courses are classified as suitable for the races themselves and do not present dangerous passages, barriers or jumps.

Art. 4 – Sport calendar and competition rules

1. All competitions referred to in Art. 3.1 must be included in the WRF Sport Calendar. The WRF international Sport Calendar must be approved by the Executive Board or the Sport Department.
2. International competitions are governed by the WRF Rules, whereas national Championships by the rules indicated in the respective National Regulations.
3. Promotional events may also be governed by special rules that, in this case, must be specified in the relevant event bulletin.

Art. 5 – Participation in competitions

1. Only athletes in possession of their National membership valid for the current year, with the approval by their National Organization, may participate in the competitions.
2. All WRF members can participate in international competitions.
3. All the athletes and para-athletes must possess the "WRF Athletes Membership" to compete in the competitions referred to in art. 3.1, Class A), B) and C). The WRF Secretariat is responsible to publish a specific handbook with the technical instructions. The "WRF Athletes Membership" doesn't replace the national membership unless otherwise stipulated by the respective National Federation.
4. Participation in competitions of people or WRF Members upon which the WRF judicial body or other international authorities recognized by the WRF have inflicted suspension, disqualification or marked them as *persona non grata* is forbidden.
5. It is prohibited, for WRF Members, to join demonstrations in stark contrast with the statutory purpose of the WRF. All breaches shall be dealt with by the WRF Justice bodies.
6. The registrations for the competitions referred to in art. 3.1, Class A), B) and C) must be done through the WRF online Platform, unless otherwise established by the WRF.

Art. 6 – Awards

1. For each category of a competition, included in the WRF Sport Calendar, an award ceremony has to be organized by the Local Organising Committee according to the WRF Protocol Guidelines.
2. Awards for first, second and third place must be given to the first three crews of each event and category. Other prizes may be awarded to competitors.

Art. 7 – WRF Ranking

1. At the end of a competition an overall ranking is established. The allocation of scores, depending on the arrival order in the event is made to the following scheme:

a. The maximum score assigned is:

RX	120
Slalom	100
Downriver	80
Total	300

b. The scores to be attributed to each team are calculated as a percentage, based on the maximum score, as follows:

first place: 100%, second place: 90%, third place: 80%, fourth place: 75%, fifth place: 70%, sixth place: 68%, seventh place: 66%, from eighth: minus 2% for each position (Annex B).

c. The general event ranking is determined by the positions of the teams, according to the total score achieved during the circuit.

2. If the international competition is included in an international circuit (e.g. Continental Cup, World Cup), the event ranking position generates a score for the general event ranking.

3. Promotional events, even if approved by the competent WRF bodies, do not generate a score.

Section II – The Parties

Art. 8 – Participation

1. Participation is allowed for registered men and women, divided into categories, as set out in the following paragraph.

2. Athletes are divided by age into the following categories:

a. **Junior:** athletes aged fifteen to nineteen in the year of reference. The Under 19 crew is made up exclusively of people belonging to this age group. Athletes in the Under 19 categories, can compete, both as single athletes and as a complete crew, in the Under23 or Senior category. It remains clear that, no matter their age, when participating in a competition in the Under23 or Senior category, all athletes will be classified in this category. Athletes belonging to this category can compete only on natural rivers of maximum class III difficulty. They can compete also on artificial and semi-artificial venues of maximum class IV difficulty.

b. **Under 23:** athletes aged fifteen to twenty-three in the year of reference. The Under 23 crew is made up exclusively of people belonging to this age group. Athletes in the under-23 category, can compete, both as single athletes and as a complete crew, in

the Senior category. It remains clear that, no matter their age, when participating in a competition in the Senior category, all athletes will be classified in this category.

- c. **Senior:** athletes aged fifteen to seventy-five in the year of reference.
 - d. **Master:** athletes aged thirty-five to seventy-five in the year of reference. Only athletes belonging to this age group can participate in this category.
3. The crews of the Under 19, Under 23, Senior and Master categories can be male, female or mixed. It is intended for female crew that composed only of women. In the competitions referred to in the art. 3.1, Class A) and B), except for the Continental Cups, it is intended for male crew that composed only of men.
 4. Mixed crews are only allowed to compete in the R4 category and consists of 2 male athletes and 2 female athletes according to categories referred to Art. 8.2.
 5. The crews must be numerically composed of 4 athletes for R4 category rafts, or 6 athletes for R6 category rafts, distributed by age groups and with the aforementioned limitations.

Art. 9 – Technical clothing and individual safety equipment

1. Every single member of the crew must wear the following clothing in good and perfect working condition:

a) Technical clothing

a.1 If the water is above 8-degree Celsius:

- at least one capilene/lycra for the chest (long or short sleeve);
- neoprene short.

a.2 If the water is below 8- degree Celsius:

- splash jacket (short or long sleeve);
- Capilene/lycra for the chest;
- Neoprene pants.

b) Mandatory security equipment

b.1 Personal Floating Device: each member of the crew must wear a buoyancy aid jacket of appropriate size to the body.

b.1.1 have a floatation of at least 50 N for all sizes;

b.1.2 no inflatable buoyancy devices are allowed;

b.1.3 have not undergone any changes and is in good working condition;

b.2 Helmet: each crew member must wear a protective helmet well secured to the head.

Helmets shall:

b.2.1 be labeled with the industrial standard "HELMET FOR WHITEWATER SPORT" e.g. EN1385;

b.2.2 not have undergone any changes and in good condition;
b.3 hard-soled and closed shoes.

2. At least one crew member must carry a flip-line no shorter than 3 meters, a knife, a whistle and a throwline no shorter than 15 meters. The throwline can also be secured to the boat. On board of any boats other than the packraft there must be a reserve paddle, except for slalom and RX competitions.
3. Clothing and equipment requirements can vary depending on the water temperature and the level of difficulty of the river where the race takes place. In this case the organizing committee is obliged to specify the recommended individual technical equipment and clothing in the event bulletin following the minimum given in the art. 9.1.
4. Each crew, before departure, must ensure that each single component of the equipment complies with the provisions of the previous paragraphs and each one is responsible for its correct maintenance throughout the duration of the race.

Art. 10 – The Chief Judge

1. The Chief Judge is appointed by the competent WRF body and, leaning on the collaboration of race officials, exercises the duties defined in the WRF Officials Handbook.
2. In particular, the duties of the Chief Judge are:
 - a. to give refereeing assignments to each WRF Judge;
 - b. to summon the Race Officials at least once before the start of the race and, subsequently, each time deemed necessary;
 - c. to inspect the race course to verify the compliance with the rules specified by the present WRF Regulation.
 - d. to lay out sample checks on athletes to verify their identity;
 - e. to ensure the compliance with the technical provisions contained in the present WRF Regulations;
 - f. to ensure, before the start of the race, that everything is prepared accordingly to the rules of these Regulations;
 - g. to notify disqualifications imposed by any race officials to the crews who infringed the rules to the Heads of Delegation;
 - h. to examine and adjudicate on complaints regarding the races or arbitral decisions presented by the Heads of Delegation;
 - i. to dismiss a judge in case of negligence;
 - j. upon completion of the race, to produce an Arbitration Report with detailed summary of the event, attaching a copy of the decisions taken, and send it as a confidential document, only to the Judicial Commission's Coordinator and WRF Secretary General, within 5 (five) days from the date of the event.

3. The Chief Judge may grant the repetition of the run to a crew who provides evidence of having been damaged where appropriate.
4. The presence of the Chief Judge and Officials is a necessary and essential requirement for the validity of any competition organized by WRF.
5. The number of Judges necessary to organize a competition is decided by Chief Judge in cooperation with the Event Manager.

Art. 11 – The Judges

1. The Chief Judge also assigns the other Officials the following tasks:
 - a) The **Boarding Judge** ensures that the rafts are in conformity with the criteria established by these Regulations, that crew members wear the protective helmet, the certified lifejacket and garments suitable for the performance of the race, denying the departure of competitors without the suitable safety equipment. In shortage of Officials, the Chief Judge can also choose a person which must be properly qualified and will work closely with other Officials.
 - b) The **Start Judge** makes sure that everyone takes off in the correct order, and does not admit at the start, by communicating it to the Chief Judge, the crews
 - not complying with safety requirement;
 - who did not show up at the starting gate at the appointed time after having been repeatedly called;
 - not wearing their bib with race number;
 - not respecting the start list order.
 - c) The **Sector Judge** monitors the course in the stretch assigned to him and ensures that the runs are conducted in accordance with the race rules. The Sector Judge makes sure that the proper penalty is signaled to the data collection center.
 - d) The **Finish Judge**: checks that competitors regularly cross the finish line and signals to the team that they have crossed the finish line by audible signal.
2. A Race Official, on the indication of the Chief Judge, may assume one or more directives functions in the same event.
3. A Race Official, during the course of the competition, absolutely cannot recall, give advice or incite competitors.

Art. 12 – The Local Organizing Committee

1. The Local Organizing Committee is coordinated by a responsible qualified person.
2. The task of organizing the competition is officially awarded to the Local Organizing Committee.

3. The head of the Local Organizing Committee, the Event Manager, assigns the tasks to the various members of the Committee, coordinating their activities carefully following the instructions issued by WRF and reporting to the Race Director.
4. The Event Manager must provide the WRF Secretary General with the information about the members of the Committee for the duration of the event in the timeframe defined in the WRF Event Handbook.

Art. 13 – Tasks of the Local Organizing Committee

1. The tasks of the Local Organizing Committee are:
 - a) to obtain, from the competent authorities, all the necessary permits;
 - b) to inform the Security Authorities;
 - c) to obtain from the competent authorities the prohibition orders of navigation or of cautious navigation for the whole period of the competition;
 - d) to set up the competition course in compliance with the provisions contained in these Regulations;
 - e) to organize all the planned and necessary meetings;
 - f) to provide assistance to the Race Director, to the Chief Judge and the race officials;
 - g) to set up a Race Secretariat able to fulfill all the tasks set by art. 14;
 - h) to predispose all the necessary forms for the correct execution of the competition;
 - i) to prepare an adequate timing service;
 - j) to prepare official video support, if requested by WRF, that must be confirmed and checked before competition by WRF representative;
 - k) to appoint the Safety Manager or to organize and manage the security area, in accordance with the present Regulations;
 - l) to predispose and organize an adequate first aid service for the duration of the event: the presence of at least a doctor and an ambulance is mandatory;
 - m) to predispose, in the vicinity of the premises dedicated to the competition secretariat, an appropriate register for official communications;
 - n) to organize continuous, timely and effective communication with the WRF Member representatives;
 - o) to take care of all the various phases of the ceremonial events and in particular those concerning the prize-giving;
 - p) to ensure that easy logistic arrangements on the competition course are made to assist the delegations;
 - q) to organize a press office capable of promoting the event at every level and to facilitate the work of the press by providing timely and comprehensive news on the progress of the event;

- r) to guarantee the presence of structures suitable for hosting the public, a suitable amplification system and a person able to provide appropriate commentary (speaker);
- s) to provide a scale suitable for the weight and the equipment needed for the measurement of rafts and the buoyancy of the lifesaver jackets;
- t) to keep, for at least 12 months following the competition, in original or copy, the whole event documentation.

Art. 14 – Race Secretariat: establishment and tasks

1. The Race Secretariat is managed by a properly skilled person, which may be assisted by other personnel.
2. The Race Secretariat must have at least one telephone line (or a mobile phone) and all the office machines/tools necessary to ensure its proper functioning as established in WRF Event Handbook.
3. During competition days, the Secretariat must be hosted in suitable premises and in the immediate vicinity of the competition area.
4. The tasks of the Secretariat are:
 - a. to manage the received registrations, according to the provisions established by these Regulations and the event bulletin;
 - b. to collect the entry fees, any eventual fines and issue the corresponding receipts;
 - c. to fill out the start lists of all the races on the program and to hand over a hard copy of it, at the time of accreditation and at least two hours before the start of the competitions to each delegation, to the Race Director, to each official and to the timekeepers (at least 2 copies);
 - d. to compile in the shortest possible time and post to the official wall of communications the complete start lists obtained during the race, to distribute a copy to the race director, to each race official and to the timekeepers (at least 3 copies);
 - e. to fill out the partial and final rankings based on the official results presented by the Chief Judge and promptly post them to the official notification;
 - f. to collect the complaint fees, retaining those related to complaints not accepted and transferring them to the WRF Secretariat;
 - g. to provide all the information on the competition to the Heads of Delegation, to the Race Director, to the competition officials, to the timekeepers and to the representatives of the various sectors predisposed from the Organizing Committee;
 - h. to provide the list of the Heads of Delegation to the Race Director and the Chief Judge;
 - i. to fill in a complete folder, in its entirety, containing the bulletins, together with all required attachments, and send it to the WRF Secretariat within 5 days from the end

of the race itself. The rankings attached to the folder will have to be signed by the Chief Judge.

Art. 15 – Race Director

1. The Race Director is appointed by the Organizing Committee, with the approval of its National Federation.
2. If the competition is a World Championships, a World Cup or a Continental Championships the Race Director is appointed by the National Federation with the approval of the WRF.
3. The Race Director must be a WRF race official or a person with a complete knowledge of the Sport Rules, approved by the WRF Secretariat. The Race Director is responsible for the general management of the competition and for this he/she interacts continuously with the Chief Judge.
4. In particular, the tasks of the Race Director are:
 - a. to check that the event takes place according to what is indicated by the WRF Rules;
 - b. to move, upon justification, the departure times, to change the race course, and, in case of prolonged persistence of the impediment, to cancel the competition. In this case the race is moved or canceled according to the provisions indicated in Art. 11;
 - c. to nominate upon the proposal of the Chief Judge and for justified reasons, the race officials;
 - d. to impose fines, to oust from the races or to take other disciplinary actions, according to WRF provisions. towards a WRF Member or athletes who, during the course of a race or during the course of the entire competition, have violated the rules of sport fairness. He/she must inform the Chief Judge of these provisions;
 - e. to inform the WRF Justice bodies of the cases where it is shown the possibility of a sport or disciplinary foul;
 - f. to decide over any other matter arising during the course of the race not ruled by WRF Regulations;
 - g. to fill the race file.
5. The decisions of the Race Director have immediate effect.
6. The Race Director must be present on the competition for the entire duration of the event and cannot participate in competitions as a competitor, in any class of boats.

Art. 16 – The Safety Manager

1. The Safety Manager, in collaboration with the rescue personnel, is entirely responsible for security during the race.
2. The Safety Manager can request the immediate interruption of the race, informing the Race Director and the Chief Judge, if he/she considers that the situation is potentially hazardous,

or if the river level reaches a certain level of danger that compromises the safety of the athletes.

3. The Safety Manager must always be present on the competition, for the entire duration of the event and cannot participate in competitions as a competitor, in any class of boats.
4. The Safety Manager may modify the technical clothing and individual safety equipment referred to in Art. 9 if necessary.

Art. 17 – Rescue Service

1. The Organizing Committee must ensure adequate rescue and assistance services in the most difficult and dangerous parts of the course.
2. The Rescue Service has to be guaranteed from the beginning of the free training sessions until the end of all races, it should consist of a large number of experienced and equipped people, with suitable equipment such as throwlines, possible anchored raft, safety kayak, etc. or other equipment necessary for ensuring maximum safety.
3. The Rescue Service is coordinated by the Safety Manager which must always be present and in contact with the Race Director for the entire duration of the event.
4. Rescue teams may withdraw from the race course and stop their operations only after receiving the notice from the Safety Manager, subject to official approval by the Race Director, that the race ended.

Art. 18 – Timing Service

1. In WRF Events the timing service must be carried out by the timekeepers of the WRF or a similar and equivalent entity, recognized and approved by the WRF or WRF Members.
2. The times recorded by the timekeepers are final.
3. Timekeeping starts the moment that the start signal is given and any part of the raft crosses the start line and finishes when any part of the boat crosses the finish/imaginary line or the system of the time-detection.
4. The detection of the race time must be made electronically with photocells, at the start and at the finish line, connected to each other and with an accuracy of one hundredth of a second on any A or B level competition.

Art. 19 – The Head of Delegation

1. Each delegation must communicate the name of the Head of Delegation during the registration procedure.

2. The Head of the Delegations is the only subject authorized to carry out, in the name and on behalf of the WRF Member, any kind of official act, required or requested during the course of the race, in strict compliance with the provisions of this Regulation.

Section III – Organisation Rules

Art. 20 – The bulletin

1. The bulletins for competitions referred to in Art. 3.1 *a) b)* must be prepared by the Local Organizing Committees on the model provided by the WRF Secretariat.

Art. 21 – The schedule

1. In the drafting of the event bulletin, in regard to the sequence of races, the interval of time between the various events and their distribution in the days of the event, one must follow the rules dictated by the present article.
2. Conducting an event when only one day of competition is scheduled.
 - a) If, in the event bulletin the carrying out of a short race (slalom or RX) and a long one (downriver) is foreseen, the short race must be scheduled in the morning and the long race in the afternoon, or vice versa. The time interval between the short and the long race must not be of less than 60 minutes.
 - b) in the Slalom the minimum time interval, between the last competitor of the first run and the departure of the first competitor of the second run must not be less than 30 minutes.
3. Conducting races scheduled over two or more days.
 - a. Over more days, it is possible to carry out all events: short races (RX and slalom) and one long race (downriver).
 - b. The time interval between the arrival of the last competitor of the qualification phase of the RX and the departure of the first pair of the “knockout” phase, must be at least 30 minutes.
 - c. If a slalom race followed by a RX race is scheduled, the time interval between end of the final of the RX or slalom race and the departure of the first competitor of the RX qualifications or slalom, must not be less than 60 minutes.
 - d. The race sequence can be reversed or modified according to the needs of the organizers.
 - e. In event bulletin, in addition to the normal indications, the duration of the events, the intervals between the same or between runs must also be indicated.

Art. 22 – Registration and entry fees

1. Registrations, according to the event bulletin, must be signed by the President of the National Federation, member concerned or by another of its managers.
2. The amounts of the registration shall be fixed by the Local Organizing Committee according to the WRF Fee System's principles.
3. The fee must be paid, under penalty of exclusion from the competition, by the WRF members to the Local Organizing Committee.

Art. 23 – Participation

1. Every scheduled event is considered valid if minimum of 3 teams come to competition and compete in same category.
2. For event to be considered international 3 different countries have to compete in the same category.

Art. 24 – Movement and cancellation of a race

1. If 72 hours before the start of an international competition, reasons of force majeure intervene in a way as to prevent the holding of the competition, the Organizing Committee must communicate the impossibility to carry out the competition itself and inform the displacement and / or cancellation of the race to all WRF Members registered and the competent WRF Bodies.
2. Any shift to a new date, in addition to being previously authorized by the competent WRF bodies, must be promptly communicated by the Organizing Committee to the WRF Executive Board through the WRF Secretariat, that shall inform about it all the WRF Members already registered. The latter cannot change their registrations but can communicate other withdrawals, which will not be sanctioned if done within a further deadline together with the notification of the new date.

Art. 25 – Accreditation of Delegations and Head of Delegations's meeting

1. The accreditation of the delegations takes place in the manner specified in the event bulletin.
2. During the accreditation procedures, each registered delegation must be present with a representative; in absence of such representative registrations are confirmed automatically.
3. During accreditation the Head of the Delegation, by means of appropriate forms, must communicate any withdrawal.

4. The schedule must be provided to all members who request it.
5. The Head of Delegation's meeting takes place in the manner specified in the event bulletin.
6. The Head of Delegation's meeting is attended by the Race Director, the Chief Judge, the head of the Organizing Committee and the Heads of the Delegations.

Art. 26 – Withdrawals

1. The withdrawal of a crew must be notified by the Head of Delegation during the accreditation phase and the decision is final.
2. The withdrawal, announced after the end of accreditation, entails a sanction set by the WRF Executive Board at the beginning of each season, payable to the WRF Secretary.
3. In case of a justified reason, the Race Director may suspend the sanction.

Art. 27 – Race bibs

1. The Local Organizing Committee (LOC) must provide the bibs with numbering. The bibs must show the numbering clearly on the chest and on the back of the competitor, and, if not on all the members of the crew, at least on one competitor sitting in the front, in the direction of motion. This decision will be communicated to the Heads of Delegations.
2. The LOC must provide the bibs of two different colors for RX competitions.
3. The numbers must be black on a white background, having at least a 15cm character of height and a body of 1.5cm.
4. Each crew must appear at the start wearing its bib and must take care of returning it at the end of the race to the Organizing Committee in accordance with the instructions given by the same.
5. The assignment of bibs to competitors shall be prepared by the Race Secretariat.

Art. 28 – Starting list

1. The starting list shall be prepared by the Race Secretariat following the indications of the Chief Judge.

Art. 29 – Publication of the results

1. When all the teams have completed their run, the Organizing Committee must, if no claims are pending, immediately put up the standings and the timing results, endorsed by the Chief Judge, on the official communication wall, positioned and visible near the finish area.
2. All results must remain posted for at least 20 minutes.

Art. 30 – Advertising on the venue

1. Subject to prior approval of the WRF, the Organizing Committee can sell advertising space to third parties, but must, in all circumstances, ensure adequate space for the sponsors of the WRF.
2. The advertising combination can happen in various ways: application of marks on bib numbers, banners display near the racecourse, advertisement on listings of programs and results, etc.
3. Competitors, crews or delegations, upon approval of the WRF, may apply marks and/or advertising writings on rafts, paddles, helmets, etc.
4. In addition to the regulations of the law and the local laws on advertising, the prohibitions dictated by the WRF must be complied with, in any circumstance.

Art. 31 – Advertising on the technical materials

1. On rafts, accessories and sportswear, brands of sponsors and advertising logos may be placed, if authorized by WRF or National Organization of belonging.
2. All the advertising material should be placed so that it cannot interfere with the identification of participants and affect the visibility of the race.
3. The inscriptions must be placed in the same position on the rubber boats and clothing of the participants.
4. The paddles can have writings on them.
5. The advertising of cigarettes and alcohol is not permitted.
6. The advertising media must be placed on the side of the boat in a space comprised between 40 and 70 cm.

Section IV – Technical Rules

Art. 32 – Course features

1. The course must be such as to avoid that competitors may be driven by the current towards dangerous areas, waterfalls, weirs, barriers, poles, channels in galleries, or other obstacles that cannot be overcome.
2. The Local Organizing Committee must remove obstacles from the path caused by the floods such as trees, floating hazards, etc. and it must properly sign the presence of any mandatory points of passage (natural or artificial) by giving notice to the Heads of delegations.

Art. 33 – Rafts features

1. Rafts must be self- emptying.
2. The boats allowed to perform competitive activity must have the following requirements:
 - a. Inflatable boats for 4 people (category R4):
 - Minimum length: 3.40 m
 - Maximum length: 4.20 m
 - Minimum width: 1.70 m
 - Transversal tube number: 2
 - Foot straps number: 4/6
 - Minimal side tube diameter: 0.40m
 - Minimum weight: 32.0 kg
 - b. Inflatable boats for 6 people (category R6):
 - Minimum length: 4.20 m
 - Maximum length: 5.00 m
 - Minimum width 2.00 m
 - Transversal tube number: 3
 - Foot straps number: 6/8
 - Minimal side tube diameter: 0.40m
 - Minimum weight: 38.0 kg
 - c. Inflatable boats for 1 person (packraft):
 - Minimum length: 1.80 m
 - Minimum width 0.90 m
 - Minimum weight: 2.0 kg
3. All inflatable boats must be equipped with an outer perimeter security rope, secured by a minimum of 8 D-rings, and one piece of rope at the front stern, with the exception of packrafts. Transport handles are allowed. Any other rope, for security reasons, is strictly prohibited.
4. Each raft must have a minimum of one "foot strap" for each athlete in the boat, with the exception of packrafts.
5. The propulsion takes place with a single-bladed paddle that must not have any fixed support point on the boat. The propulsion of the athlete in R1 category takes place with a double-bladed paddle.
6. The bottom must be equipped with security valves, made of soft material and preferably secured with ropes rather than glued.

7. Each participant is free to use his paddle, oars are forbidden.
8. The crew of each raft cannot exceed the maximum limit set by the boat manufacturer.
9. In the competitions referred to in the art. 3.1, Class A) and B), except for the Continental Cups, only the raft models approved by WRF according to the Annex C can be used, unless otherwise established by the WRF Executive Board.

Art. 34 – Starting provisions

1. The starts for the various events can be done in one of two ways:
 - a) **individual starts**, i.e. per single boat:
 - 1) competitors must be in due time near the starting gate and, having confirmed their presence, must place themselves in an ideal position for the start;
 - 2) the start takes place with the raft in a stationary position, preferably held in position by a Start Judge's assistant;
 - 3) each competing crew, and for each event, must be notified locally or with an acoustic signal 10 seconds before the start; the order "PADDLES OUT OF THE WATER" is then given and, at the discretion of the Start Judge, the last 5 seconds are counted. The departure is signaled with a beep or the pronouncing aloud "Go";
 - 4) a false start is determined by the unquestionable judgment of the Start Judge.
 - 5) starts are set at intervals of at least 1 minute;
 - b) **in-line starts**:
 - 1) this type of departure must be performed in a stretch of river that has a space along the shore with weak current, wide enough to place all of the rafts, one next to the other;
 - 2) the crews, whose members must all be on board, or all on the ground, or with a single member on the ground to hold the raft and the others on board (the type of start must be communicated during the Heads of Delegations' meeting), are roll-called and aligned in an upstream with respect to the starting line, and then led in formation, slowly, towards the start line itself;
 - 3) when the Start Judge sees that the boats are essentially stationary and aligned, in the water or on the shore, he draws the attention of competitors with a command, immediately followed by a beep or the uttering aloud the word "GO";
 - c) **group starts**:
 - 1) if it becomes necessary, due to lack of space on the shore, and inability to ensure an in-line departure, it is possible to accord departures by groups of rafts. Crews are notified 10 seconds before the start. The order " PADDLES OUT OF THE

WATER" is then given and, at the discretion of the Start Judge, the last 5 seconds are counted. The departure is signaled with a beep or the pronouncing aloud "GO;

- 2) the number of groups and crews per group are determined by the number of registered competitors and space available at the start;
 - 3) the composition of the groups, the order of departure and their position is determined by the Race Director by drawing and/or according to the time or score obtained in the previous races;
- d) **"Knockout" starts**, departures for RX events; the two departing rafts are positioned in a stretch of river where both may have the same current conditions and are retained by two of the Start Judge' assistants. From the starting line, a stretch of the course, determined by the Race Director, must be divided into two lanes to avoid that for that stretch the rafts and/or crews make contact. 3 seconds before departure, all members of the crew, must have no paddles in contact with the water. Each competing crew, and for each event, must be notified locally or with an acoustic signal 10 seconds before the start; the order "PADDLES OUT OF THE WATER" is then given and, at the discretion of the Start Judge, the last 5 seconds are counted. The departure is signaled with a beep or the pronouncing aloud "Go";
2. The start mode for each event must be communicated during the Heads of Delegations' meeting.
 3. The paddles cannot touch the water 5 seconds before the start; this rule doesn't apply to any event organized with the so called "fly-start".

Art. 35 – Conducts during the course

1. The participants take part in races at their own risk.
2. Before the start of the race any race official may check the safety equipment of each crew.
3. Crews who do not meet the security requirements are not allowed to start as long as the same are not met. After the next control, once compliance to safety requirements is proven, they will be allowed to start in the queue to all the other crews.
4. Participants of a crew may be disqualified if they do not meet the safety requirements within a predefined time assigned to them.
5. The Safety Manager has the right to stop a race at any time, if there are risks to crews and/or for those involved in the service itself, while immediately informing the Race Director and the Chief Judge.
6. In safety issues, the Safety service takes the final decision.
7. If those involved in the security service ask a raft to stop or cooperate in a given situation, a specific audible signal must be given and it must be respected by all. This type of signal must be communicated to the Heads of Delegations before the race itself. The crew that

- does not respect the instructions of the Safety service or who shows negligence to their own or others' safety may be disqualified from the race.
8. The organizers of the event or race are not responsible for accidents or damage that may occur during the race.
 9. Each participant, including the organization personnel and every single competitor, must always behave in a conscious and correct manner, in order to minimize the risks of accidents or damage.
 10. Flipping does not constitute a ground for disqualification if the overturned boat is returned to its original position, and all team members are inside the raft before the finish line.
 11. Crossing the finish line does not give rise to penalties when the same is crossed by the raft in the original position and with the whole crew on board i.e., for category R6, with six people on board, for the category rafts R4, with four members on board. On board means that no part of the body, except the torso, touches the water.
 12. During races it is required to give way to incoming rafts and facilitate the passages. In the races of the Slalom and in Downriver, not giving way to oncoming boats and intentionally not facilitating the overtaking shall be punished with 10 seconds, to be added to the total race time or even with disqualification if considered intentional by Chief Judge.
 13. The crews of the incoming raft must get the attention of the crew of the boat which they intend to overtake and point towards which side they want to make the passing.
 14. The crew of the boat reached by another competitor should not hinder the progress of the coming raft and has an obligation to pull on the side indicated by the coming raft; the latter has the obligation to notify out loud to the overtaken crew, "CAUTION, STEP RIGHT" or "CAUTION, STEP LEFT", giving them time to pull over on the side.
 15. When a raft is about to be overtaken by another, if a field Judge is present, he whistles repeatedly and the competitor that is being passed must give way.
 16. The Chief Judge, in the presence of an accepted claim or on the recommendation of the Sector Judge, in slalom races, can let a crew repeat its run, if blatantly obstructed.
 17. The crews of stuck rafts or that stopped for interlocking on rock along the racecourse are required to vacate the race course as quickly as possible. In case the operation proves difficult and represents a situation of danger for the oncoming rafts, a crew member must move up the stationary raft, in a visible position to oncoming and report the obstacle according to the code of the marks of the river (paddle raised horizontally above the head).
 18. The crew that during the race loses one or more team members, is required to rescue them from the water before continuing the race.
 19. In case a crew member can no longer continue the race due to injuries, the other team members can continue the run only when the injured person has been handed over to the medical or security personnel

20. For the peculiarity of some races, it is possible that a boat is in a situation of difficulty and danger in a point of the course where it is impossible for the rescue services to intervene; It is, in this case, required that oncoming crews stop to provide immediate help to anyone in obvious difficulty.

Art. 36 – Loss or damage of the paddle

1. When a contestant loses or breaks a paddle, he/she can only use the spare paddle placed on the boat.

Art. 37 – Flipping of the boat

1. A crew is considered flipped when the boat is overturned and the members have completely exited from it; in this case, crew members can reset the boat into race mode and continue the race.

Art. 38 – Race Suspension

1. Before the start or during the course of the race, on the recommendation of the Race Officials, in case of serious and proved dangers, the Race Director must suspend and postpone the competition until the danger has passed.

Art. 39 – Measures of disqualifications

1. The Race Officials, for purely technical infringements, disqualify crews which:
 - a) do not comply with competition rules;
 - b) at a check are guilty of having raced with a boat not compliant with the regulations and/or not complying with the safety requirements;
 - c) receive external aid not allowed by the Regulation of the race. External aid meaning:
 - 1) directly helping a competitor in the race on the boat in order to facilitate final results;
 - 2) passing a spare paddle to a competitor in the race;
 - 3) having the raft managed, pushed or moved by a third party;
 - 4) giving signs to a competitor by means of radio-transmitting equipment.
2. Disqualifications must be notified by the Chief Judge to the Head of Delegation immediately after the conclusion of the race concerned.
3. Should the Representative, called several times, not appear before the Chief Judge in the 15 minutes following the first call, the suspension becomes final.

Art. 40 – Complaints

1. The complaints (Annex D) regarding the holding of a competition or arbitrary decisions must be issued and signed by the Head of the Delegation to the Chief Judge in the written form within 20 minutes from the publication on the wall for official communications, of the race standings concerned.
2. A complaint concerning the RX knockout stage may be brought against a decision of the Judges within 4 minutes from the end of the run.
3. Together with the complaint referred to in paragraph 1, the Head of Delegation or any other Official Delegation Member must pay the complaint fee, which will be refunded if the complaint is upheld. In the absence of the payment of the fee, contextual to the complaint, the latter cannot be accepted.
4. The Chief Judge must notify the Head of Delegation or the Other Official Delegation Member of his/her decision in the 20 minutes following the presentation of the claim.
5. In order to prove claims, during the examination of the complaint, evidence must be submitted, consisting of the WRF official video, WRF official photographs or WRF official footage. If the Local Organizing Committee doesn't provide with an official video with the resolution defined in the WRF International Event Handbook (HD Resolution), covering the spot where the claim happened, any personal video is admissible.
6. Personal video materials have to show clearly the infringement or the lack of one, have to unquestionable determine the position of the team on the race course
7. In any case, for the complaints regarding the Downriver any personal video is admissible.
8. After reviewing materials, accepting or not accepting complaint, is the decision of Chief Judge and this decision is final.
9. If complaint is accepted necessary steps to best rectify situation are determined by Chief Judge.
10. Complaint against a complaint cannot be submitted.
11. The acceptance of a complaint absolutely excludes the cancellation of the race.

Section V – Particular requirements for RX races

Art. 41 – Definition

1. The purpose of the RX race is to complete, in the shortest possible time, a course between two crews starting simultaneously and with a system of knockout elimination.
2. The RX descent must be carried out in a river section where "scouting" can be done along its path, where both crews find themselves, possibly, in conditions of the same difficulty

level and current and where the line of departure allows them to start in the same circumstances.

3. The RX is made up of two phases: the first phase, the so called *timed sprint*, determines the draw for the second phase, the *knockout phase*.
4. On the basis of the results and the number of participants in the timed sprint, only a limited number of teams can access directly to the second stage of the race; all others must complete the first phase of the race to gain access to the second. The Race Director may establish a maximum number of teams that access to the second stage.
5. The model Knockout System determines the knockout draw on the basis of the timed sprint's results according to the Art. 46.

Timed Sprint

Art. 42 - Timed sprint

1. The purpose of the first phase, the timed sprint, is to complete a course on whitewater in the shortest possible time. The maximum length of the whitewater race stretch is of 600m.
2. This phase consists of a single run.

Art. 43 - Timed sprint's start

1. The start intervals must be between one minute and two minutes between a crew and the next one.
2. A false start is determined by the unquestionable judgment of the Start Judge. In this case team in question will receive 10 penalty seconds to their race time.
3. The individual start procedures are defined in Art. 34.1 lett. a).

Art. 44 - Timed sprint's arrival

1. The finish line (arrival) is to be shown in a very obvious manner on both banks of the river.
2. The boat cannot cross the finish line more than once, or go back along the race course after finishing the race. Breaches of this rule automatically brings to the disqualification of the crew concerned.
3. Where it is necessary to place a gate for the support of the photocells, it is mandatory that the rafts cross it internally.
4. When a boat crosses the finish line with an incomplete crew, it is disqualified.

Art. 45 - Timed sprint's rankings

1. The order of arrival is drawn up taking into account the time taken by the crew to complete the entire course, adding the penalty assigned.
2. If two or more competing crews finish the timed sprint with the same time, the first position for the second phase is defined by coin toss. If there are 3 or more teams with the same times, the best position is defined by the lower bib number.
3. If the position is relevant for the passage to the knockout stage, a playoff (a second run of a timed sprint) between the teams with the same times is organized. If more teams finish the playoff with the same time, the rules referred to art. 45.2 will apply.

Knockout phase

Art. 46 – Knockout phase

1. The formula to determine, the crews that will directly access the knockout phase and those that will have to go through the first knockout phase is the following:

$$\mathbf{A - B = C}$$

$$\mathbf{B - C = D}$$

Where:

A = Powers of 2 (2, 4, 8, 16, 32, 64, 128, 356 etc.) from which the number of crews that completed the timed sprint must be deducted

B = number of crews that completed the timed sprint

C = number of crews that automatically go to second stage

D = number of crews competing in the first knockout stage

2. In the knockout phase the teams with the fastest time in the timed sprint will have the priority in choosing their starting position.
3. Late show up or no show up at the starting gate leads to victory of the opposing team.
4. The starting positions of the two crews in the knockout stage must be chosen in the most equal manner possible so that the lines are identical for both teams.

Art. 47 – Course

1. The maximum distance of the course must be of 600m.
2. No contact area. In the first part of the course a no contact area is set up. This no contact area begins at the start positions and end at the orange pole positioned no less than 10 meters from the starting line.

3. An orange pole or a buoy indicates the point from which the contact is allowed. The rafts must cross this pole within the time defined by the Chief Judge (First Contact Time). The First Contact Time must be presented by the Chief Judge during the Heads of Delegations' meeting.
4. In the course upstream and downstream gates are installed according to the Art. 48.
5. A penalty pair of upstream gates is installed in the last section of the RX course. It should be set no further than 50 meters and no closer than 10 meters from the finish line.

Art. 48 – Gates

1. The gates don't touch the water. Gates to be negotiated downriver, in favor of the current, are marked by green stripes. Gates to be negotiated upstream, against the current, are marked by red stripes. The pole must have a maximum height of 2.00 m, a round section with a diameter between 5cm and 7cm, have a sufficient weight not to be moved by the wind and be constructed with a plastic pipe (PVC) or wood.
2. The upstream gates are distributed in pairs along the course and signaled by a single pole. Only one gate in each pair must be negotiated: each crew is free to decide which gate to negotiate in each pair.
3. Downstream gates are distributed along the course and signaled by a single pole.
4. The number of upstream gates along the RX course must be of 1 (one) pair or 2 (two) pairs, not including the penalty pair of upstream gates referred to in Art. 47.11.
5. The number of downstream gates along the RX venue must be 1 (one) or 2 (two).
6. Contact with the pole is allowed. The pole shall not be moved intentionally.
7. To consider a regular gate passage, the following conditions must occur:
 - a. all heads of all crew members have crossed the gate line together on the correct side, according to the design of the track and appropriate direction of the gate;
 - b. all crew members have to be in the raft.
8. After a regular passage, the crew is allowed to cross the same gate line again.

Art. 49 – Penalty

1. A penalty gate is imposed to the team by the Judges:
 - a. when a crew invades the other competitor's lane in the no contact area with any part of the boat, or with the body of a member of the crew and any other equipment available before point from which it is allowed;
 - b. when the crew touches the orange pole, indicating the end of the no contact area, with any part of the boat, or with the body of a member of the crew and any other equipment;
 - c. in the case of obstruction of the opposing team with the paddle;

- d. when the contact with the gate is intentional.
2. A double penalty gate is imposed to the team by the Judges when a crew skips a gate.
3. For each penalty the crew has to complete one of the penalty gates, turning around the pole, the number of times equal to the number of penalties imposed. The number of times cannot exceed three (3).

Art. 50 – Elimination

1. “Elimination” means that the team eliminated shall lose automatically the round and shall be ranked at the bottom of its phase group. Both the opposing teams could lose the round.
2. The team is eliminated when:
 - a. a fourth penalty is imposed;
 - b. when the penalty gate is skipped by one or more crew members;
 - c. when the passage of the finish line takes place with the raft with an incomplete crew.

Art. 51 – Disqualification

1. “Disqualification” means that the team disqualified shall lose all standings from the RX event and shall be ranked as “DSQ”.
2. The team is disqualified and, accordingly, will not be inserted in the final ranking when:
 - a. any member of the crew grabs a rope of the other boat;
 - b. any member of the crew grabs an athlete of the other boat;
 - c. any member of the crew spaces two attached rafts by hand;
 - d. a violent physical contact, that aims to create a risk or damage to the other crew, is considered unsportsmanlike by the Judge;
 - e. the crew does not perform or complete the full length of the course, it will be disqualified.

Art. 52 – Start of the knockout phase

1. The start occurs at a rate of a minimum of 2 and a maximum of 4 minutes between a pair of crews and the next.
2. In case of false start the opposing team automatically wins.

Art. 53 – Arrival of the knockout phase

1. The finish line (arrival) is to be shown in a very obvious manner on both banks of the river or above the river where possible.

2. Where it is necessary to place a gate for the support of the photocells, it is mandatory that the rafts cross it internally.

Art. 54 – Rankings

1. The final ranking of the race is filled out as follows:
 - a. Final A: the winners of the semi-final race will compete to determine the 1st and 2nd position; the winner will occupy the 1st place, the loser, the 2nd place;
 - b. Final B: the losers of the semi-finals will meet to determine the 3rd and 4th place, the winner will occupy the 3rd place, the loser, the 4th place. If Final B can't be carried out, 3rd and 4th place will be determined by uncleared penalties and best time that the two losers had obtained in the semi-final elimination; the least uncleared penalties and best time will occupy the 3rd place, while the higher time will occupy the 4th place.
2. The final position of the other teams, for the purposes of the general ranking, is determined by their position against the opposing team eliminated in the same phase and taking into account uncleared penalties and best time obtained at that stage; least uncleared penalties and best time will occupy the ranking positions starting from 5th place downward. The four teams eliminated in the quarter-finals are classified, for their least uncleared penalties and best time obtained in that phase; the least uncleared penalties and best time will occupy the ranking position from 5th to 8th place and so on. The number of uncleared penalties is first determining factor and time is used as tie breaker.

Section VI – Particular requirements for the Slalom races

Art. 55 – Definition

1. The purpose of the race, which is held in two runs, is to travel in the shortest time possible a distance that requires the crossing of gates, in the ascending numerical order of the gates, trying to avoid touching the poles or the skipping of the gates themselves.
2. The slalom race takes place on two runs on the same race course. It's mandatory to take part in both the runs. For the allocation of points, the best among the two is considered.

Art. 56 – The course

1. The distance for a Slalom race, between the start and finish, should not exceed 600m.
2. The course must be navigable for its entire length, have natural obstacles and/or artificial that can be always overcome and provide equal conditions for all rafts.

3. The race course is designed by the Route Planner(s), appointed by the Race Director.
4. The Route Planner(s) must ensure that the path originally conceived is maintained such for the whole duration of the race: they are responsible for the adequate arrangement of the gates and of further equipment and must be ready to perform changes and adjustments proposed by the Race Director.
5. If, during the race, a change in the water level such as to distort the result occurs, the Chief Judge must stop the race itself until the water conditions are not returned to normal.
6. If during the race occurs a momentary factor that alters the characteristics of the course occurs, the Chief Judge may authorize changes or movements of the gates, that will have to ensure even conditions among competitors.

Art. 57 – Starting Orders

1. The final order of departure with the names of the crews, their affiliation and race numbers shall be delivered to the Heads of the Delegations, to the Chief Judge and other Race Officials.
2. The program must be compiled respecting the order and the intervals between races, as pointed out in these Regulations.

Art. 58 – Route Approval

1. At least one hour before the race, the course must be approved by the Race Director.
2. Upon request of any Heads of the Delegations, the Race Director may consider proposals for route changes related to excessive difficulty of the track or safety reasons.

Art. 59 – Start

1. The start occurs on average at a rate from a minimum of two (2) minutes at a maximum of five (5) minutes between a crew and the next one.
2. Competitors must be on time near the station of departure, and after confirm their presence, they must settle into an ideal position.
3. The rafts must be disposed in the sense of the current and/or, if the river conditions so require, in countercurrent.
4. The start takes place with stationary raft, preferably held in position by a Start Judge' assistant. The individual start procedures are defined in Art. 34.1, lett. a) .
5. The false start, as defined in Art. 34.1 lett. a.4), is determined by the unquestionable judgment of the Start Judge. In this case team in question will receive 10 penalty seconds that will be added to their race time.

Art. 60 – Gates

1. The gates are formed by a suspended pole. The downstream, in favor of the current, are indicated by 5 (five) green rings and from 5 (five) white rings, alternating between them; the rings are 20cm high, the poles must always end with the white ring. The upstream, against the current, are marked by 5 (five) red rings and 5 (five) white rings, alternating each other; the rings are 20cm high, the poles must always end with the white ring. The poles must have a maximum height of 2.00m, a round section with a diameter between 5cm and 7cm, have a sufficient weight not to be moved by the wind and be constructed with a plastic pipe (PVC) or wood.
2. Signs positioned above the gates, number them progressively, according to the design of the predisposed race course. They measure cm. 30x30cm. They feature a yellow background with numbers in black, 20cm. high and to 2cm thickness, shown on both sides and crossed by a diagonal red line red 2cm thick on the opposite side to the direction of the correct passage of the gate.
3. The Gate Judges, from their position, must clearly see the signs that mark the gate of their competence and must occupy a position from which they can easily witness the correct passage or error committed by a competitor.
4. The number of gates along the slalom route must be of at least 8 (eight) and maximum of fourteen (14), of which a minimum number of 2 and a maximum of 6 must be upstream, evenly distributed on the right and left banks of the left of the river or channel.

Art. 61 - Passing the gates

1. All gates must be overcome in accordance with the numerical sequence and the direction established, as indicated on the signs that indicate the number.
2. All gates must be overcome respecting the correct side of passage.
3. The passage of the gate begins, and the gate is active, when:
 - a. a raft or the body or the head of one or more members of the crew or the paddle touches the pole of the gate;
 - b. any of competitors head crosses the gate line.
4. The passage of a gate ends, and gate ceases to be considered active, when:
 - a. the passage of the next door begins, like described in the subparagraph 3;
 - b. crossing the finish line.
5. Even the start and arrival lines are considered, likewise, as the gate line.
6. To consider a regular door passage, the following conditions must occur:
 - a. all heads of all crew members have crossed the gate line on the correct direction, according to the design of the track, without touching any pole with the body, with the paddles or with the raft;

- b. heads of all competitors crossed the line between riverside and pole in proper direction i.e. they must pass between the pole and the riverside and in the proper predetermined direction.
- c. heads of all competitors must pass through the gate while all off the competitors are inside of the boat
- d. in case of upstream gates team is performing continuous advancement through the gate.

Art. 62 – Penalty

1. In a slalom race are the following penalties assigned:
 - a. "0" points-seconds: with correct passage carried out without making mistakes. No crew member, with the head or torso, must pass in way different from the one indicated; if this happens, the gate is considered activated, for which, even if the crew try again to execute it correctly, a penalty of "50" points-second would occur.
 - b. "5" points-seconds: when the passage of the gate is correct, but one or more crew members touch one or more times the pole of the gate. Repeated touches of the same pole are penalized only once.
 - c. "50" points-seconds:
 - i. when one or more crew members touches the pole without properly passing the gate;
 - ii. when one or more crew members intentionally push the pole to facilitate passage. The action is not considered intentional when the bodies of the crew and the boat are already in a position where they would have the ideally passed the gate;
 - iii. when a crew crosses the gate line with the boat overturned;
 - iv. when a crew crosses the gate line in the wrong direction from that indicated on the map of the course and on the pole;
 - v. when during the passage of the gate line, any part of the body of one or more crew members crosses the gate line in the wrong direction;
 - vi. when a competing crew skips the passage of the gate. The gate is considered skipped when a crew skips crossing a gate, passing to the next one in ascending numerical order;
 - vii. when a gate is skipped by one or more crew members;
 - d. The passage of the raft under the pole of the gate (crossing the gate) without touching cannot entail a penalty.
 - e. Subsequent passages in the already overcome gate does not involve penalties if next gate has been activated, even if the pole was to be touched.

- f. If one or more crew members disembark the raft to release the boat from an obstacle (tie) to continue the course, it does not involve penalties.
 - g. If one or more crew members realize that they are not able to pass an ascending gate with the paddles, it is possible, if the river so permits, that one or more crew members descend from the boat, approaching, pulling or pushing the boat up close to the gate; later, before starting to move to the gate line, cross it and proceed with the correct passage, all crew members must get on board and go through the gate properly, paddling. If a member or several members of the crew are not on board, or if, crossing the gate line, the chest or the head of one or more members are not properly within the pole, the crew will be penalized with 50 (fifty) points-second; the same penalty will be assigned in the case in which the crew is not able to pass the gate, in which case the door itself will be considered skipped.
 - h. If, on the contrary, in a valid passage, one or more touches of the pole occur, these will be penalized with 5 (five) points-second once.
 - i. The passage of the gates must always occur with the full crew (onboard) ie n. 4 people for R4 and n. 6 people for R6.
 - j. It is possible to give competitors the benefit of the doubt.
2. 50 points-seconds the maximum possible penalty imposed for each gate.

Art. 63 – The Gate Judges

1. They verify the passages assigned to them by indicating the penalties and communicate them to the Competition Secretariat with the appropriate means. If the route has grouped gates, 2 or more door controllers are required at the respective stations.
2. Gate Judges must not call competitors who have committed a penalty or incite them.

Art. 64 – Signals for Gate Judges

1. Discs or visible signs should be used to indicate the penalties to the public.
2. Each Gate Judge is equipped with a red disc (20 cm. diameter) or a sign (20 cm side), with the handle of 40cm length, colored on both sides, with the figures 50 (in black) and a disk or yellow sign with the digit 5 indicated on both sides.
3. The Gate Judge uses the signals in the following cases:
 - a. the passage of the gate occurred with penalization of 5 seconds; in this case the Gate Judge raises the yellow disc with the figure corresponding to the penalty;
 - b. the passage of the door has not been carried out correctly, with a penalty of 50 seconds; in this case the Gate Judge raises the red disc with the figure corresponding to the penalty;

Art. 65 – Arrival

1. The finish line (arrival) is to be shown in a very obvious manner on both banks of the river.
2. The raft cannot cross the finish line more than once, or go back along the course after finishing the race, this causes disqualification.
3. Where it is necessary to place a gate for the support of the photocells, it is mandatory that the rafts cross it internally.

Art. 66 – Ranking

1. The result is given by the time taken in seconds in the best between the two runs, adding the penalties assigned for respective runs.
2. The penalty points, converted into seconds are added to the race time.
3. If two or more competing crews finish a race with the same score, they are classified *ex-aequo*.

Art. 67 – Obstacle on the course

1. Where, during the passage of a gate, the overtaken raft hinders an oncoming boat, the Sector Judge obliges the overtaken boat to leave the passage to the oncoming raft, by emitting a prolonged whistle.

Section VII – Particular requirements for the Downriver races

Art. 68 – Definition

1. The aim of the Downriver race is to paddle along, in the direction of the current, a pre-established stretch in the shortest possible time, overcoming the technical difficulties that the path provides.

Art. 69 – Distances

1. The path must provide for a minimum length of 3000 meters, maximum of 7,000 meters
2. The path must be navigable in its total length.
3. The course shall be approved by the Race Director, who has the right to choose, taking into account the water level of the moment, an alternative race course.
4. No intentional physical contact (paddle against paddle, person against person, person against paddle/raft) is allowed at any stage of the race. It shall be punished with 10 seconds,

to be added to the total race time or even with disqualification. In case of multiple 10 second penalties, they are added together.

Art. 70 – Start

1. The starting modes are defined in Art. 34.
2. The false start, as defined in Art. 34.1 lett. a.4), is determined by the unquestionable judgment of the Start Judge. In this case team in question will receive 10 penalty seconds that will be added to their race time.

Art. 71 – Arrival

1. The finish line (arrival) is to be shown in a very obvious manner on both banks of the river.
2. The boat cannot cross the finish line more than once, or go back along the path after finishing the race. Breaches of this rule automatically brings to the disqualification of the crew concerned.
3. Where it is necessary to place a gate for the support of the photocells, it is mandatory that the rafts cross it internally.
4. When a boat crosses the finish line with an incomplete crew, it is disqualified.

Art. 72 – Rankings

1. The order of arrival ranking is drawn up taking into account the best time achieved.
2. If two or more competing crews finish a race with the same score they are ranked *ex-aequo*.

Annex A

1. The Para-Rafting crews must be numerically composed of 4 athletes.

LTA	LTA means Amputee (Class 3): legs, torso, arms can work
The crew must be composed of 2 LTA Amputee Athletes and 2 able-bodied athletes	

OC	<p>OC means “Open category”</p> <p>The eligible Impairments are the following:</p> <ul style="list-style-type: none"> • Visual Impairment Class B3 (the least severe visual impairment eligible, the highest visual acuity and/or a visual field of less than 20 degrees radius) • Hearing Impairment (Deaf athletes) • Intellectual disabilities
The crew must be composed of 2 disabled athletes and 2 able-bodied athletes	

2. In the bulletin of each event or by decision of the WRF Secretary General, the WRF can modify the sport rules, laid down in this document, taken into consideration the circumstances of the case.

Annex B

	RX	Slalom	Downriver
1° place	120	100	80
2° place	108	90	72
3° place	96	80	64
4° place	90	75	60
5° place	84	70	56
6° place	82	68	54
7° place	79	66	53
8° place	77	64	51
9° place	74	62	50
10° place	72	60	48
11° place	70	58	46
12° place	67	56	45
13° place	65	54	43
14° place	62	52	42
15° place	60	50	40
16° place	58	48	38
17° place	55	46	37
18° place	53	44	35
19° place	50	42	34
20° place	48	40	32
21° place	46	38	30
22° place	43	36	29
23° place	41	34	27
24° place	38	32	26
25° place	36	30	24
26° place	34	28	22
27° place	31	26	21
28° place	29	24	19
29° place	26	22	18
30° place	24	20	16

Annex C

The aim of these regulations is to regulate the use of raft in WRF competitions by ensuring equal treatment of Clubs, WRF member National Federations, manufacturers and sponsors in a spirit of fair play and support the rapid and unambiguous identification of players by the race officials and spectators.

Definitions

Manufacturer

A company that designs, produces (directly or through a non-branded licensee) and sells products bearing its own manufacturer trademarks for use in the sports market. Suppliers and other entities that distribute such products are not considered manufacturers.

Manufacturer composite mark

Any sign, device or logo made up of a combination of a manufacturer word mark and a manufacturer design mark in one single representation.

Sponsor trademark

The element of sponsor advertising that is either (a) registered as a trademark at a national or supranational trademark registry within the territory of a WRF member National Federation, or (b) amounts to an indication of sponsorship origin (i.e. *it allows a reasonable person to identify the sponsor as the business responsible for the sponsor advertising*).

WRF Manufacturers scheme

The WRF Manufacturers scheme allow rafts manufacturers to register with the WRF and provide a prototype of their competition raft to be approved by WRF.

Since 1 April 2021 all new competition rafts manufactured by registered WRF rafts manufacturers must have an WRF Manufacturers label permanently fixed into the inside surface of the raft in plain view that cannot be removed or tampered with in any way. These labels can only be purchased by manufacturers registered with the WRF Rafts Manufacturers Scheme.

Example Label:



All competition rafts constructed by registered WRF Rafts manufacturers must conform to all of the following specifications. Any breaches of these specifications will result in the immediate suspension of that manufacturers license for the period of time decided by the WRF Executive Board. During this time, no rafts built by that manufacturer will be permitted WRF sanctioned events.

Rafts Specifications

Minimum weight: 30 kg

Maximum weight: 35 kg

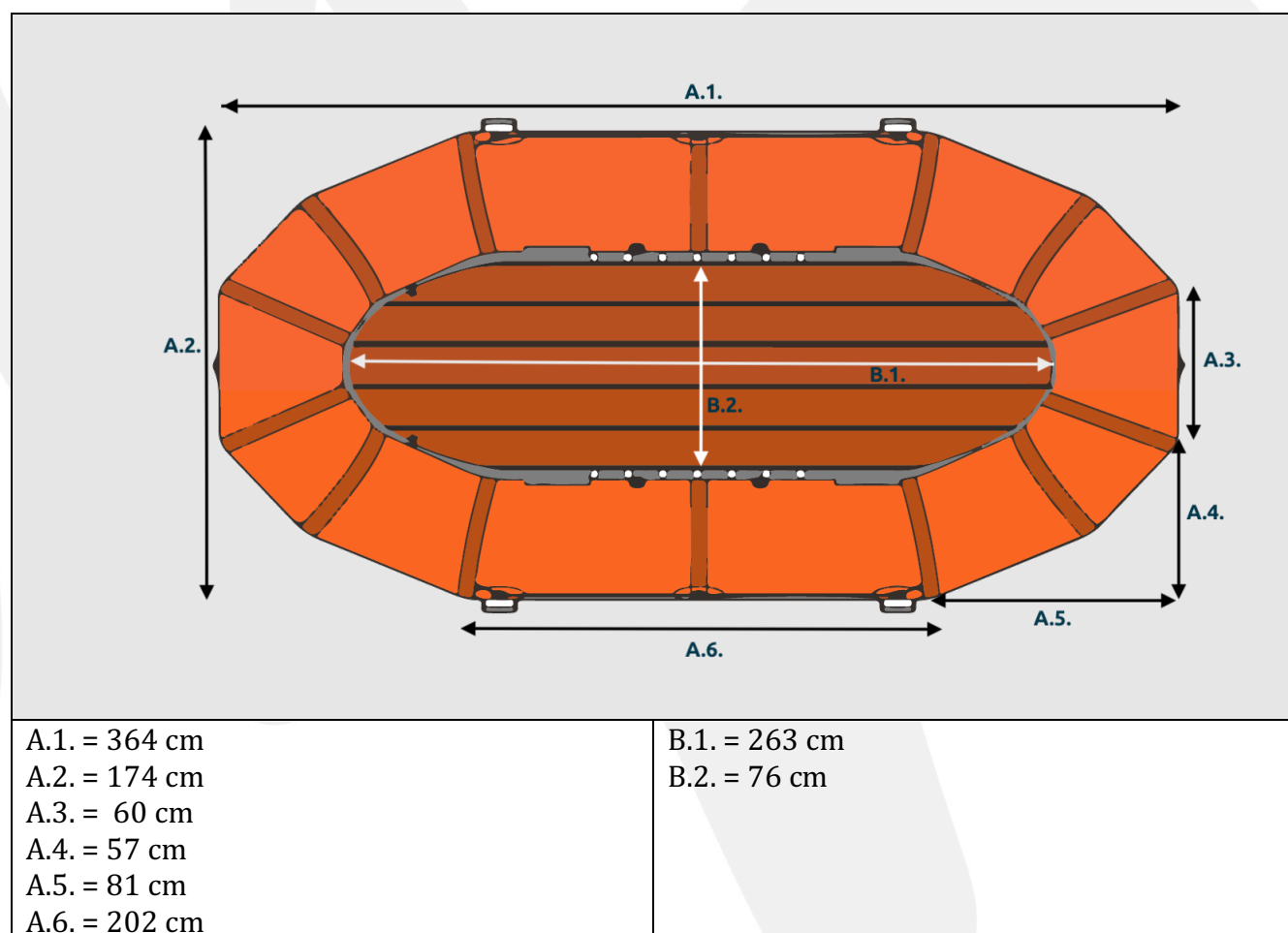

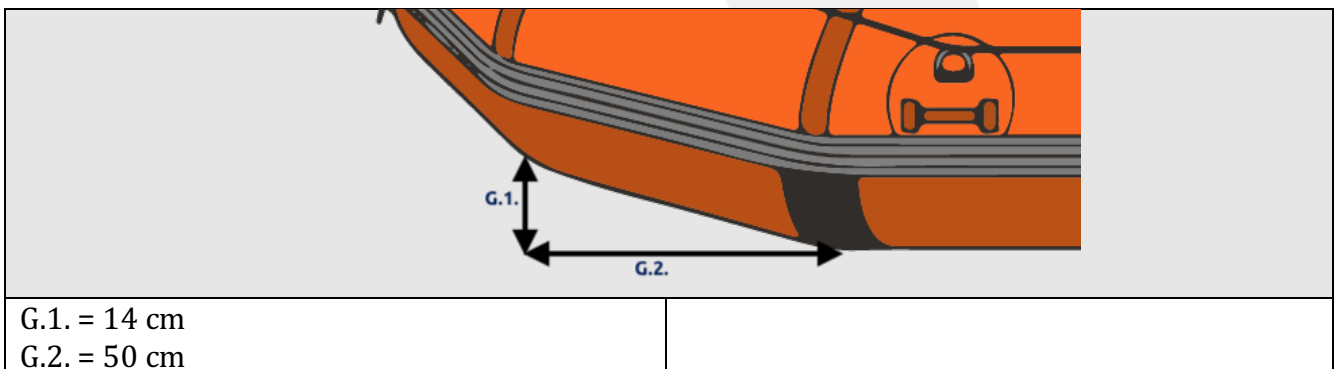
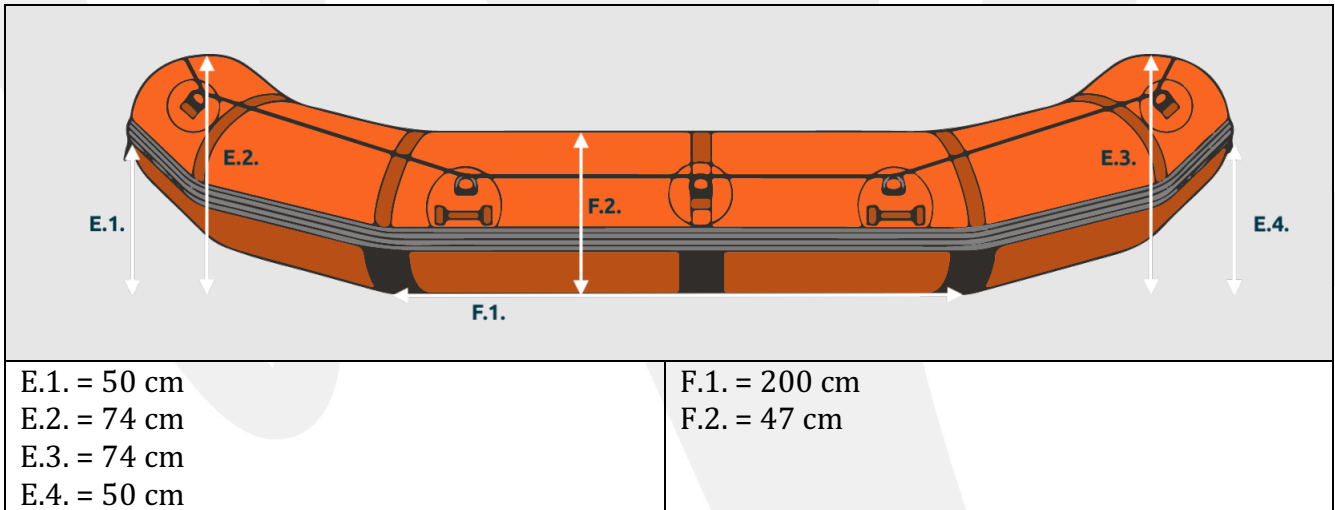
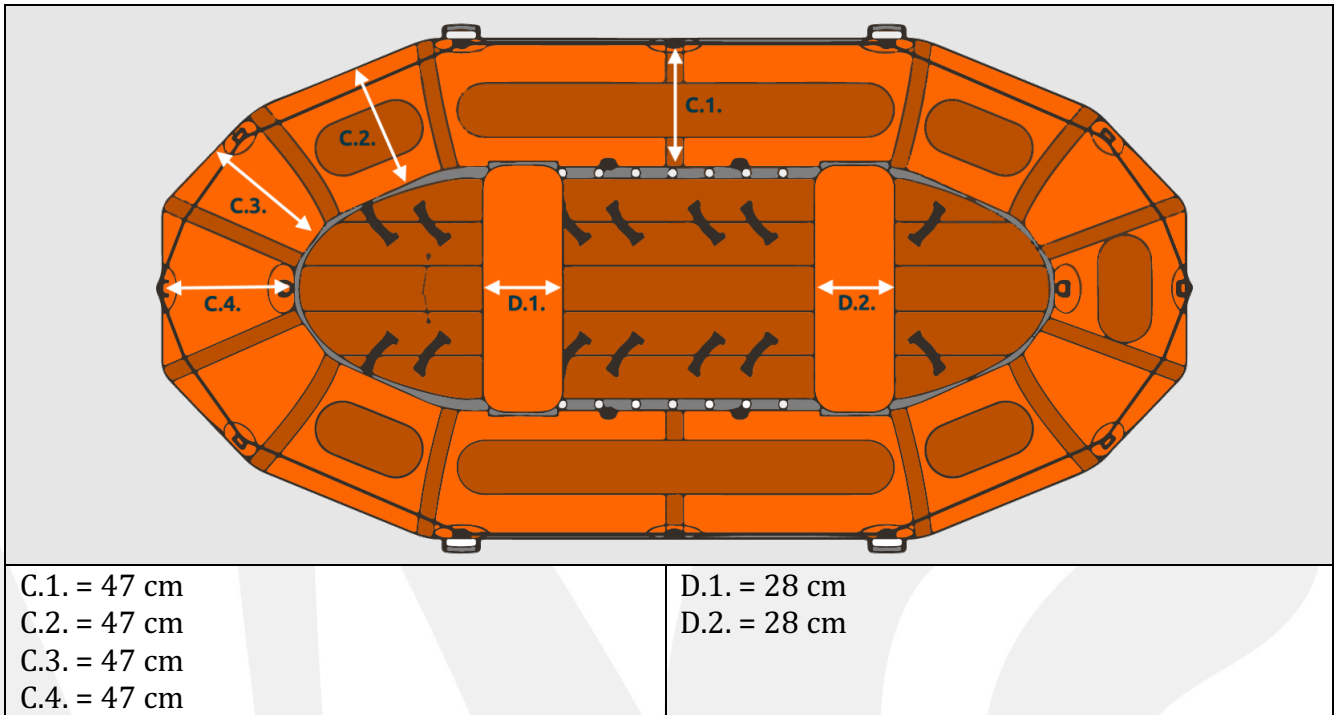

Manufacturer composite mark (maximum n. 2 on the external side of the raft) must not touch each other or any other element displayed on raft.

Sponsor trademark identifications (maximum n. 2 on the external side of the raft) must not touch each other or any other element displayed on raft.

How to register

- Send an email to secretariat@worldraftingfederation.com with all relevant contact details and your Manufacturer composite mark.
- Send a prototype to WRF Headquarter and Secretariat – **Fraz. Neyran Dessus, 4, 11020 Brissogne (AO), Italy.**

Once the WRF has approved the prototype, the WRF Headquarter will then ratify and sign the documents to complete the process. As part of the agreement with the WRF, the manufacturer must guarantee the following:

- every raft manufactured will have an WRF license label permanently fixed into the construction of the raft inside the raft where damage is minimal;
- every competition raft manufactured will meet the current WRF Specifications;
- any raft found to breach these specifications will result in a suspension of the WRF Manufacturer status for the builder of the rafts and all rafts they manufacture will also be banned from all WRF events for the period of time decided by the WRF Executive Board.

Annex D

Complaint

A complaint against a decision of the Judges must be addressed to the Chief Judge of the jury in writing and must be accompanied by a fee of 75 euro (or an equal amount in another currency). The complaint must be handed to the Chief Judge no later than the time indicated in the Sport Rules.

Complaint

Received

Date Time

_____ : _____

Signature - Team Leader

Signature – Chief Judge

Decision of the Chief Judge

The Chief Judge has decided to uphold your complaint _____

The Chief Judge has decided to reject your complaint because:

The decision is final.

Signature – Chief Judge
