

UNITED RAFTING SPORT RULES

TABLE OF CONTENTS

Section I – General Rules 5

 Art. 1 – Purpose..... 5

 Art. 2 – Fight against doping..... 5

 Art. 3 – Disciplines 5

 Art. 4 – Competition Formats..... 5

 Art. 5 – Classic Format..... 6

 Art. 6 – Adventure Format..... 6

 Art. 7 – Classification of competitions 6

 Art. 8 – Competition Calendar..... 7

 Art. 9 – Event validity 7

 Art. 10 – Awards 8

 Art. 11 – World Ranking and Event Overall Ranking..... 8

Section II – The Athletes 10

 Art. 12 – Eligibility and participation 10

 Art. 13 – National Teams 10

 Art. 14 – Club Teams 10

 Art. 15 – Division 11

 Art. 16 – Team composition..... 11

 Art. 17 – Age categories 11

Section III – Technical Rules 13

 Art. 18 – Technical clothing and individual safety equipment 13

 Art. 19 – Rafts features..... 13

 Art. 20 – Starting procedures..... 14

 Art. 21 - Specific procedure for RX and H2H..... 15

 Art. 22 - Specific start procedure for Downriver 15

 Art. 23 – Finish procedures..... 16

 Art. 24 – Conducts during the course 16

 Art. 25 – Loss or damage of the paddle..... 17

 Art. 26 – Race Suspension..... 17

 Art. 27 – Measures of disqualifications..... 17

 Art. 28 – Protests 18

Section IV – Particular requirements for Sprint..... 20

 Art. 29 – Definition..... 20

Art. 30 – Sprint’s start and arrival.....	20
Art. 31 – Timed sprint’s rankings.....	20
Section V – Particular requirements for RX.....	21
Art. 32 – Definition.....	21
Art. 33 – Knockout phase.....	21
Art. 34 – RX Course.....	21
Art. 35 – RX Gates.....	22
Art. 36 – RX Penalty.....	22
Art. 37 – Elimination.....	23
Art. 38 – Disqualification.....	23
Art. 39 – Start and arrival of the knockout phase.....	23
Art. 40 – Rankings.....	23
Section VI – Particular requirements for the Head-to-Head.....	24
Art. 41 – Definition.....	24
Art. 42 – Venue and Course Requirements.....	24
Art. 43 – Competition Stages and pairing.....	24
Art. 44 – Ranking.....	24
Art. 45 – Course Design.....	24
Art. 46 – Navigation Markers and Positioning.....	25
Art. 47 – Marker Negotiation.....	25
Art. 48 – Marker Design.....	25
Art. 49 – Hanging Marker Design.....	25
Art. 50 – Safety.....	26
Art. 51 – Penalties.....	26
Section VII – Particular requirements for the Slalom.....	27
Art. 52 – Definition.....	27
Art. 53 – The Slalom course.....	27
Art. 54 – Starting Orders.....	27
Art. 55 – Slalom’s start and arrival.....	27
Art. 56 – Gates.....	27
Art. 57 – Passing the gates.....	28
Art. 58 – Penalty.....	28
Art. 59 – Overtaking.....	29
Art. 60 – Ranking.....	30

Section VIII – Particular requirements for the Downriver	31
Art. 61 – Definition.....	31
Art. 62 – Distances	31
Art. 63 – Downriver’s start and arrival.....	31
Art. 64 – Downriver penalties.....	31
Section IX – Organization Rules	32
Art. 70 – Officials (Jury and Judges)	32
Art. 71 – Race Director	32
Art. 72 – The Local Organizing Committee.....	32
Art. 73 – The Safety Manager and the rescues service.....	33
Art. 74 – Timing service.....	34
Art. 75 – The bulletin	34
Art. 76 – Movement and cancellation of a race.....	34
Art. 77 – Accreditation of Delegations / Teams	35
Art. 78 – The Head of Delegation / Team Captain meeting.....	35
Art. 79 – Race bibs.....	35
Annex A – Para-Rafting	36
Annex B – Point system.....	38
Annex C – Raft homologation procedure	41
Annex D – Protest form.....	45

Section I – General Rules

Art. 1 – Purpose

1. This document sets forth the rules and regulations governing rafting sport competitions and is developed and maintained by United Rafting.
2. The primary objective of these Sport Rules is to ensure fair play, a universally recognized principle that forms the very foundation of all sporting activity. Beyond fairness, these rules are intended to uphold and promote the fundamental values of good sportsmanship, including respect, equality, integrity, tolerance and excellence.
3. Should any provision of this document appear to conflict with another, or if its meaning is ambiguous or unclear, the principles of fair play, respect, equality, integrity, tolerance and excellence shall prevail and guide the interpretation, thereby determining the underlying intent of the rule.

Art. 2 – Fight against doping

1. Doping is strictly prohibited and appropriate health checks on the athletes may be performed according to what is established by United Rafting, IOC and WADA.
2. The lists of doping substances categories and doping methods correspond to those approved by WADA and IOC.
3. Random checks may be performed both by the competent Authority and the United Rafting.

Art. 3 – Disciplines

1. The official disciplines recognized by United Rafting are the following:
 - a) RX (Rafting cross);
 - b) H2H (Head-to-Head);
 - c) Slalom;
 - d) Sprint;
 - e) Downriver.
2. The technical, sporting and organisational rules governing the above-mentioned disciplines are set forth in the present Sport Rules.
3. These Rules shall also apply to Para-Rafting activities, unless otherwise expressly provided. Any specific adaptations or exceptions applicable to Para-Rafting shall be set out in Annex A, which forms an integral part of these regulations.

Art. 4 – Competition Formats

1. United Rafting recognizes that the sport of rafting comprises competitive activities characterized by differing technical, environmental and organizational features. In order to ensure clarity, consistency and international uniformity in the conduct of competitions, United Rafting formally establishes two international competition formats: the Classic Format and the Adventure Format.
2. A competition format defines the structural and operational framework under which international events are conducted, including, but not limited to, course typology, eligibility requirements, discipline composition and sequencing, team structure, scoring

systems and adjudication standards. All international events shall be organized and conducted in accordance with the provisions of the present Rules and in compliance with the specific requirements set out in the implementing documents thereto (the “Event Requirements Handbook”).

3. Unless otherwise expressly provided by discipline-specific or event-specific regulations, the definitions and provisions governing the Classic Format and the Adventure Format shall apply to all United Rafting competitions.

Art. 5 – Classic Format

1. Competitions conducted under the Classic Format may include, individually or in combination, the following disciplines:
 - a) Sprint;
 - b) Rafting Cross (RX);
 - c) Slalom.

Art. 6 – Adventure Format

1. Competitions conducted under the Adventure Format shall include, individually or in combination, the following disciplines:
 - a) Sprint;
 - b) Head-to-Head (H2H);
 - c) Slalom;
 - d) Downriver.

Art. 7 – Classification of competitions

1. Competitions organized within the framework of United Rafting are classified as follows:
 - Class A**
 - a) Classic World Championships;
 - b) Adventure World Championships;
 - Class B**
 - a) Classic Continental Championships;
 - b) Classic or Adventure World Cup events;
 - Class C**
 - a) Classic or Adventure Continental Cups;
 - b) International competitions recognized by United Rafting;
 - Class D**
 - a) National Championships;
 - Class E**
 - a) National events recognized by National Federation;
 - b) Local or regional events recognized by the National Federation.
2. Competitions classified under Class A, Class B, and Class C shall be sanctioned by United Rafting, in accordance with the present Regulations and the applicable Event Requirements Handbook.
3. Competitions classified under Class D (National Championships) shall be sanctioned by the respective National Federation, which shall notify the United Rafting Secretary of the event dates within the timelines established by United Rafting.

4. National Championships may be reclassified as Class C international events where such competitions are formally opened to international teams. Such reclassification shall be subject to prior written application by the relevant National Federation and formal approval by United Rafting.
5. Upon approval, the event shall assume the official designation “Open of [Name of the Country]” and shall be governed by the rules applicable to Class C competitions.
6. Competitions classified under Class E) shall be sanctioned by the respective National Federation.

Art. 8 – Competition Calendar

1. The Classic R4 Senior World Championship shall be organized every two (2) years in odd-numbered calendar years. Participation is limited to the Senior category, and all competitions shall be conducted exclusively using R4 rafts.
2. The Adventure R6 or R4 Club World Championships shall be organized every two (2) years in even-numbered calendar years. The competition is open to Master, Senior, Under-23 (U23), and Junior (U19) categories. Events may be conducted using R4 and/or R6 class rafts, as specified in the event regulations approved by United Rafting.
3. The Classic R4 Junior (U19) and U23 World Championship shall be organized every two (2) years in even-numbered calendar years. The event is open to athletes competing in the Junior (U19) and Under-23 (U23) categories and shall be conducted exclusively using R4 class rafts.
4. The Classic Continental Championships shall be organized every two (2) years in even-numbered calendar years. Participation is restricted to the Senior category, and competitions shall be conducted exclusively using R4 class rafts.
5. World Cup events shall be organized on an annual basis. Participation is restricted to the Senior category, and all competitions shall be conducted exclusively using R4 class rafts, in accordance with the applicable World Cup regulations.
6. Classic or Adventure format Continental Cup events shall be organized annually and shall be open to athletes competing in the Senior, Under 23 (U23) and Junior (U19) categories.
7. National Championships may be organized annually and shall be open to athletes competing in the categories established by the organising National Federation. The raft class or classes to be used shall be determined by the organising National Federation and, where required, approved by United Rafting in accordance with the applicable Regulations.
8. Upon a reasoned proposal from the Sport Department, the Board of Directors may approve exceptions to the aforementioned provisions.

Art. 9 – Event validity

1. For an event to be considered international 3 different countries have to compete in the same division.
2. If the number of Teams or Member Nations entered in an Event are less than the required minimum number, an Organizer may apply for an exception to the Sport Department to have the Event considered valid.
3. It is not necessary that the required minimum number of Teams or Member Nations finish in all of the disciplines of the Event for the results to be valid.

Art. 10 – Awards

1. For each competition category included in the United Rafting Sport Calendar, an award ceremony shall be organized by the Local Organizing Committee (LOC) in accordance with the United Rafting Protocol Guidelines. Awards for first, second and third place shall be presented to the top three teams in each age category and division.
2. In Classic and Adventure Format competitions, titles and official recognitions shall be awarded separately for each discipline.
3. In Adventure Format competitions, the Sprint discipline shall be conducted exclusively as a qualifying race for the Head-to-Head (H2H) phase; no points or awards shall be assigned for this discipline.
4. In the Adventure and Classic Senior World Championships, a trophy shall be awarded to the team finishing in first place in the overall combined classification of all disciplines.

Art. 11 – World Ranking and Event Overall Ranking

1. The final ranking positions achieved at Class A), B), C) and D) events included in the United Rafting Calendar shall generate points for the World Ranking.
2. Points shall be allocated according to the finishing order of the event, in accordance with the following scheme:
3. The maximum score assignable per discipline is as follows:

RX	100 points
Head-to-Head	100 points
Slalom	100 points
Downriver	100 points
Sprint (only if the event is held in Classic Format)	100 points

The maximum total score achievable per event is 300 points.

4. Points awarded to each team shall be calculated as a percentage of the maximum score, as follows:
 - 1st place: 100%
 - 2nd place: 90%
 - 3rd place: 80%
 - 4th place: 75%
 - 5th place: 70%
 - 6th place: 68%
 - 7th place: 66%
 - from 8th place onward: a reduction of 2% per position

The score obtained at an event shall be multiplied by an event value factor, determined according to the event level classification, as defined in Annex B.

5. In order for an event to be considered valid for World Ranking purposes, it must be officially sanctioned and/or recognized by United Rafting and duly included in the official United Rafting Calendar. For the validity of the scoring, registrations must be processed through The Flow system or, in cases expressly authorized, collected in compliance with the technical requirements established by United Rafting.
6. Official results, in the format prescribed by United Rafting, must be submitted within 48 hours of the conclusion of the event.

7. At the end of each calendar year, the overall World Ranking shall be determined for both Nations and athletes, based on the total national score accumulated during the competitive season.
8. Promotional events, even if approved by the competent United Rafting bodies, shall not generate World Ranking points.

Section II – The Athletes

Art. 12 – Eligibility and participation

1. All United Rafting National Members are entitled to participate in international competitions.
2. Only athletes holding a valid national membership for the current calendar year, issued by their respective National Federation, may participate in competitions.
3. In order to participate in Class A), B), C) and D) events, all athletes and para-athletes must hold a valid United Rafting Athlete License, in accordance with the provisions set out in the annual official communication published by United Rafting.
4. The United Rafting Athlete License does not replace the national membership requirement, unless otherwise expressly stipulated by the relevant National Federation.
5. Participation in competitions is strictly prohibited for any individual or United Rafting Member who is subject to a suspension, disqualification or declaration of *persona non grata*, imposed by a United Rafting judicial body or by any other international authority recognized by United Rafting.

Art. 13 – National Teams

1. Classic World Championships and Classic Continental Championships are competitions reserved exclusively for National Teams.
2. National Teams must be entered in such events by the National Secretariat or other duly authorized bodies of the respective National Federations. Specific provisions apply to teams participating under the Developing Program.
3. Athletes selected for National Teams shall be chosen through transparent selection procedures, based on objective criteria established by the respective National Federations. Such criteria shall be communicated to the athletes well in advance of the relevant competitions.
4. Any competitor participating in the Classic World Championships or Classic Continental Championships must be a national of the country of the National Federation entering that competitor.
5. A competitor who holds the nationality of two or more countries simultaneously may elect to represent any one of them. However, once a competitor has represented a country in the Classic World Championships or Classic Continental Championships, they may not represent another country within the same calendar year.
6. From the following calendar year onward, subject to written notification to United Rafting no later than 31 December, the competitor may request authorization to represent the other country of nationality. Upon approval, the competitor shall represent that country for a minimum period of three (3) consecutive years.
7. Each Delegation shall appoint a Head of Delegation and a Vice-Head of Delegation, both of whom shall be duly accredited for the Event.

Art. 14 – Club Teams

1. All competitions other than the Classic World Championships and the Classic Continental Championships shall be events reserved for Club Teams.
2. Club Teams must be affiliated with or recognized by their respective National Federation.

3. In order to participate in Class A, B, and C events, Club Teams must hold a valid United Rafting Club Licence, in accordance with the provisions set out in the annual official communication published by United Rafting.
4. Athletes competing as members of a Club Team may be of different nationalities; however, all athletes must hold a valid national membership for the current calendar year issued by the National Federation with which the Club Team is affiliated or recognized.
5. Each Club Team shall appoint a Team Captain, who shall be duly accredited for the Event.

Art. 15 – Division

1. Competitions shall be organized in the following recognized divisions: Men, Women, Mixed and Para-Rafting. The divisions scheduled for the event shall be specified in the official Event Bulletin.
2. Teams entered in the Women’s Division shall be composed exclusively of female athletes. For competitions held in Class A and Class B, teams entered in the Men’s Division shall be composed exclusively of male athletes.
3. The Mixed Division is permitted exclusively in the R4 category. Teams entered in this division shall be composed of two (2) male athletes and two (2) female athletes plus one (1) male or female reserve athlete. In all cases, a minimum of two (2) female athletes and one (1) male athlete shall be at all times in the raft during the competitions.
4. The Para-Rafting Division is permitted exclusively in the R4 category. Teams entered in this division shall be composed, regardless of gender, of two (2) para-athletes, in accordance with the applicable eligibility criteria, and two (2) additional non-para-athletes, plus one (1) reserve athlete, who may be a para-athlete or a non-para-athlete. In all cases, a minimum of two (2) para-athletes and one (1) non-para-athlete shall be at all times in the raft during the competitions.
5. Competitors are permitted to race in more than one Division during a single Event if they meet the qualification requirements. In all instances, the competitor must comply with all race rules and requirements. No race shall be delayed or rescheduled to accommodate the Competitor.

Art. 16 – Team composition

1. Teams must be composed of 4 athletes for R4 category rafts or 6 athletes for R6 category rafts, distributed according to age groups and respecting the following limitations.
2. Each R6 Team or R4 Team is permitted one Reserve, who must be registered as a Team Member prior to the start of the Event.
3. The final 7 (R6) or 5 (R4) Team Members cannot be changed after they are officially registered at the Event. Until the time of accreditation, in the case of a documented injury and upon payment of the registration fee, a substitution may be requested.

Art. 17 – Age categories

1. Competitors may participate in a United Rafting Event in the calendar year in which they turn 15 years old. For Class C or D Level events, underage Competitors may participate only if approved by the National Federation of the host nation. In such cases, the venue must be age-appropriate and all necessary safety precautions must be implemented.

2. An athlete may compete in a United Rafting Event during the calendar year in which they reach the age of 14, provided that the Event Bulletin expressly states that the course includes no rapids exceeding Class III. In Class A), B) and C) events, no more than one 14-year-old athlete may be permitted in the same raft.
3. A Competitor who is legally defined as a Minor (typically a person under the age of 18) must comply with all domestic laws and regulations applicable to Minors at the Event and must be supervised by an adult (Team/Delegation Member) who assumes full responsibility. National Federations shall ensure that their Competitors comply with all laws and regulations governing Minors in their home country.
4. Athletes are divided into the following age categories:
 - a) Junior (U19): athletes are eligible to compete in the Junior category if they are 19 or younger on 31 December of the calendar year in which the competition takes place. An Under 19 team must consist exclusively of athletes within this age group. Athletes in the Under 19 category may also compete, individually or as a complete team, in the Under 23 or Senior categories. Regardless of age, athletes competing in the Under 23 or Senior categories will be classified in that category;
 - b) Under 23 (U23): athletes are eligible to compete in the U23 category if they are 23 or younger on 31 December of the calendar year in which the competition takes place. An Under 23 team must consist exclusively of athletes within this age group. Athletes in the Under 23 category may also compete, individually or as a complete team, in the Senior category. Regardless of age, athletes competing in the Senior category will be classified in that category;
 - c) Senior: athletes are eligible to compete in the Senior category if they are 15 or older on 31 December of the calendar year in which the competition takes place;
 - d) Master: athletes are eligible to compete in the Senior category if they are 40 or older on 31 December of the calendar year in which the competition takes place. Only athletes within this age group may participate in the Master category.
5. Individual Competitors may be entered and compete in more than one Age Category within the same Event. A Team, however, shall not be entered in, nor compete across, more than one Age Category within a single Event. For the purposes of this Regulation, a Team shall be deemed to be competing in multiple Age Categories where more than two (2) Athletes from the same Team are entered in, or compete in, more than one Age Category. Any breach of this Regulation shall result in the automatic cancellation, ex officio, of the Team's entries in the additional Age Categories.

Section III – Technical Rules

Art. 18 – Technical clothing and individual safety equipment

1. Every single member of the team must wear the following clothing in good and perfect working condition:

a) Technical clothing

A.1 Where the water temperature is below 8°C, athletes shall wear the following minimum mandatory equipment:

- splash jacket (short or long sleeves);
- thermal base layer (Capilene or Lycra) covering the torso;
- neoprene trousers or dry pants.

A.2 Where the water temperature is 8°C or above, athletes shall be responsible for using apparel appropriate to the prevailing environmental and water temperature conditions.

Technical clothing may vary depending on the water temperature and the level of difficulty of the river on which the competition is held. In such cases, the Local Organising Committee shall specify the recommended individual technical equipment and clothing in the Event Bulletin, in compliance with and without prejudice to the minimum requirements set out in art. 18.1.A).

B) Mandatory security equipment

B.1 Personal Floating Device: each member of the team must wear a buoyancy aid jacket of appropriate size to the body.

B.1.1 have a floatation of at least 50 N for all sizes;

B.1.2 no inflatable buoyancy devices are allowed;

B.1.3 have not undergone any changes and is in good working condition;

B.2 helmet: Each team member must wear a proper whitewater protective helmet, securely fastened, that has not been altered and is in good condition;

B.3 hard-soled and closed shoes.

2. In all competitions, at least one team member must carry a flip-line no shorter than 3 meters, a knife, a whistle and a throwline no shorter than 15 meters. The throwline can also be secured to the boat. Exceptions may be granted by the Safety Manager, provided that the competition is conducted on an artificial or semi-artificial venue.
3. Each team, before departure, must ensure that each single component of the equipment complies with the provisions of the previous paragraphs and each one is responsible for its correct maintenance throughout the duration of the competitions.

Art. 19 – Rafts features

1. Rafts must be self- emptying.
2. The boats allowed to perform competitive activity must have the following requirements:
 - a. Inflatable boats for 4 people (category R4):
 - Minimum length: 3.40 m
 - Maximum length: 4.20 m

Minimum width: 1.70 m
 Transversal tube number: 2
 Foot straps number: 4/6
 Minimal side tube diameter: 0.40m
 Minimum weight: 30.0 kg

b. Inflatable boats for 6 people (category R6):

Minimum length: 4.20 m
 Maximum length: 5.00 m
 Minimum width 2.00 m
 Transversal tube number: 3
 Foot straps number: 6/8
 Minimal side tube diameter: 0.40m
 Minimum weight: 38.0 kg

3. All inflatable boats must be equipped with an outer perimeter security rope, secured by a minimum of 8 D-rings, and one piece of rope at the front stern, with the exception of packrafts. Transport handles are allowed. Any other rope, for security reasons, is strictly prohibited.
4. Each raft must have a minimum of one "foot strap" for each athlete in the boat.
5. The propulsion takes place with a single-bladed paddle that must not have any fixed support point on the boat. The propulsion of the athlete in R1 category takes place with a double-bladed paddle.
6. The bottom must be equipped with security valves.
7. Each participant is free to use his paddle, oars are forbidden.
8. In the competitions referred to Class A) and B) held in the Classic format, only the raft models approved by United Rafting according to the Annex C can be used, unless otherwise indicated in the Event Bulletin. Each team shall be solely responsible, at its own expense, for providing a raft that complies with the approved format and the applicable United Rafting technical rules. Multiple teams may use the same raft, provided it complies with United Rafting regulations. No race shall be delayed or rescheduled to accommodate competitor requests related to raft management, availability, or logistics

Art. 20 – Starting procedures

1. The starting line shall at all times be clearly indicated by visible markers (buoys and/or flags) positioned on each side of the river and, where conditions permit, by a large banner spanning the river with the word 'START' clearly displayed
2. The start of all races shall be clearly announced using the following countdown procedure: 1 minute, 30 seconds, 20 seconds, 10 seconds, and 'paddles up' (issued five (5) seconds before the start). At '0', the start signal shall be sounded. The start signal must be loud and clearly audible.
3. Where the start interval is one (1) minute or less, the countdown may commence at one (1) minute, thirty (30) seconds, or twenty (20) seconds, as required
4. Where possible, all race starts shall be conducted from a stable pontoon.
5. For Sprint and Slalom events at Class A) and B) events, timing shall commence when the team passes the photocell positioned a few meters downstream from the starting position.

6. For RX, Head-to-Head (H2H) and Downriver events, timing shall commence at the start signal.
7. In the event of a false start, the Chief Starter may immediately stop the race and impose a penalty on the responsible Team. In Sprint, Slalom, Head-to-Head (H2H), and Downriver events, a false start results in a time penalty of at least ten (10) seconds; in RX events, it results in the assignment of two (2) penalty gates.
8. In the case of a second false start caused by the same Team the Chief Starter must disqualify the Team from this particular race. If it is not possible to do a restart the Jury should add a penalty or disqualify the team that did the false start.
9. If a raft becomes defective during a race, no re-run of the race will be granted.

Art. 21 - Specific procedure for RX and H2H

1. For RX and Head-to-Head (H2H) events, the two rafts shall be positioned in a section of the river where both are subject to identical current conditions and shall be held in place by two assistants to the Start Judge.
2. For RX events, a *no-contact zone* shall be established in the initial section of the course. This no-contact zone shall begin at the starting positions and shall end at an orange pole or buoy positioned no less than ten (10) metres downstream from the starting line. The orange pole or buoy shall indicate the point from which contact between rafts is permitted. The rafts must cross this marker within the time limit defined by the Head Judge (the *First Contact Time*). The First Contact Time shall be communicated by the Head Judge during the Heads of Delegations' Meeting. This procedure shall not be mandatory for Head-to-Head (H2H) events.
3. The start mode applicable to each event shall be communicated during the Heads of Delegations' Meeting or the Captains' Meeting.
4. Paddles shall not touch the water during the three (3) seconds preceding the start signal. This requirement shall not apply to events conducted using a so-called 'sailing start.'

Art. 22 - Specific start procedure for Downriver

1. Races shall normally be started in groups of four (4) to eight (8) rafts, depending on venue conditions. Where venue conditions permit more than eight (8) rafts to start simultaneously, this configuration shall be used. Where safety considerations or river width do not allow more than one team to start at the same time, teams may be started individually.
2. The Start Line shall be as fair as possible for all Teams. Where venue conditions do not allow equal starting positions, Teams shall be permitted to select their starting position in order from highest-ranked to lowest-ranked, based on the total points achieved in previous races or stages.
3. Where multiple start groups are raced consecutively, the highest-ranked Teams shall compete in the first heat, the next highest-ranked Teams in the second heat, and so on. The interval between consecutive groups shall be no less than one (1) minute.
4. *Le Mans* starts may be used where the venue includes a beach or similar area with sufficient space for Competitors to run to rafts positioned along the shoreline. Rafts shall be lined up in accordance with each Team's ranking. All Competitors shall remain behind a clearly marked line until the start signal is given.

5. *Sailing* starts may be used where the venue provides sufficient space for all rafts within a start group to cross the Start Line side by side. Teams may approach the Start Line at any speed; however, any Team crossing the Start Line before the start signal is given shall be penalized with a False Start.
6. For sailing starts, Teams shall be released toward the starting area individually at five (5) second intervals, with the highest-ranked Team released first, in order to provide a limited advantage in line selection. By way of example, the first Team shall be released thirty (30) seconds before the start signal, the second Team at twenty-five (25) seconds, and so forth.
7. To prevent False Starts, except in the case of Le Mans or sailing starts, each raft shall be held in position by a Pre-Starter. Teams failing to present themselves at the start on time may forfeit the race

Art. 23 – Finish procedures

1. The Finish Line shall be clearly indicated by visible markers positioned on the riverbanks (poles, flags and/or buoys) and, where conditions permit, by a large banner spanning the river with the word 'FINISH' clearly displayed
2. Photocells shall be used whenever possible for timing at the Finish Line.
3. A Team shall be deemed to have correctly crossed the Finish Line when the raft crosses the line in its original upright position and all paddlers are inside the raft.
4. For the purposes of these Rules, a paddler shall be considered “inside the raft” when their body weight is fully supported by the raft (sitting, kneeling, standing, or lying), with both feet out of the water and not in contact with any other supporting surface. A paddler shall be considered “outside the raft” at any time when these conditions are not met
5. A single time penalty of fifty (50) seconds shall be applied if, at the moment the raft crosses the Finish Line, one or more paddlers are not inside the raft and/or the raft is upside down. Under no circumstances shall multiple penalties be cumulative for these infractions. In RX events, either of the above violations shall result in elimination of the Team.
6. A raft shall not cross the Finish Line more than once, nor shall it re-enter or proceed back along the race course after finishing the race. Any breach of this rule shall result in automatic disqualification of the Team concerned.
7. Where a gate is installed to support photocells at the Finish Line, rafts shall be required to pass through the gate on the correct side and entirely between the gate markers

Art. 24 – Conducts during the course

1. The participants take part in races at their own risk.
2. Before the start of the race any race official may check the safety equipment of each team.
3. Teams who do not meet the security requirements are not allowed to start as long as the same are not met.
4. Participants of a team may be penalized if they do not meet the safety requirements within a predefined time assigned to them.
5. The Safety Manager has the right to stop a race at any time, if there are risks to teams and/or for those involved in the service itself, while immediately informing the Race Director and the Head Judge.
6. In safety issues, the Safety Manager takes the final decision.
7. If those involved in the security service ask a raft to stop or cooperate in a given situation, a specific audible signal must be given and it must be respected by all. This

type of signal must be communicated to the Heads of Delegation and/or Teams directly before the race itself. The team that does not respect the instructions of the Safety service or who shows negligence to their own or others' safety may be disqualified from the race.

8. The organizers of the event and/or race are not responsible for accidents or damage that may occur during the race.
9. Each participant, including the organization personnel and every single competitor, must always behave in a conscious and correct manner, in order to minimize the risks of accidents or damage.
10. Flipping does not constitute a ground for disqualification if the overturned boat is returned to its original position, and all team members are inside the raft before the finish line.
11. The Head Judge, in the presence of an accepted claim or on the recommendation of the Sector Judge, in slalom races, can let a team repeat its run, if blatantly obstructed.
12. The teams of stuck rafts or that stopped for interlocking on rock along the racecourse are required to vacate the race course as quickly as possible. In case the operation proves difficult and represents a situation of danger for the oncoming rafts, a team member must move up the stationary raft, in a visible position to oncoming and report the obstacle according to the code of the marks of the river (paddle raised horizontally above the head).
13. The team that during the race loses one or more team members, is required to rescue them from the water before continuing the race.
14. In case a team member can no longer continue the race due to injuries, the other team members can continue the run only when the injured person has been handed over to the medical or security personnel
15. For the peculiarity of some races, it is possible that a boat is in a situation of difficulty and danger in a point of the course where it is impossible for the rescue services to intervene; It is, in this case, required that oncoming teams stop to provide immediate help to anyone in obvious difficulty.
16. No intentional physical contact is permitted at any stage of the race. This includes, but is not limited to, contact in the following forms: paddle-to-paddle, paddle-to-person, paddle-to-raft, person-to-person, or person-to-raft.

Art. 25 – Loss or damage of the paddle

1. In the event that an athlete loses or breaks a paddle, he or she may use only the spare paddle carried on the boat or the paddle of another team member.

Art. 26 – Race Suspension

1. Before the start or during the course of the race, on the recommendation of the Officials and/or Safety Manager, in case of serious and proven dangers, the Race Director must suspend and postpone the competition until the danger has passed.

Art. 27 – Measures of disqualifications

1. For purely technical infringements, the Officials shall disqualify teams from the race in which the infringement occurred if the teams:
 - A) fail to comply with competition rules;

- B) are found, during a check, to have raced with a boat not compliant with the regulations and/or not complying with the safety requirements;
- C) receive external aid not allowed by the Regulation of the race. External aid meaning:
 - 1) directly helping a competitor in the race on the boat in order to facilitate final results;
 - 2) passing a spare paddle to a competitor in the race;
 - 3) having the raft managed, pushed or moved by a third party, except where such intervention is required for safety reasons;
 - 4) giving signs to a competitor by means of radio-transmitting equipment.
- 2. Disqualifications shall be formally communicated by the Head Judge to the relevant Head of Delegation or Team Captain without delay upon the completion of the race concerned. Such notification may be effected by duly indicating the disqualification on the official results board or electronic display.

Art. 28 – Protests

1. Protests (Annex D) concerning the conduct of a competition or alleged arbitrary decisions shall be submitted in writing to the Jury and shall be duly issued and signed by the Head of Delegation, or, in club team competitions, by the Team Captain, within ten (10) minutes from the posting of the provisional results on the official notice board, unless otherwise expressly provided for RX.
2. A Protest concerning the RX knockout stage may be brought against a decision of the Judges within 5 (five) minutes from the end of the match.
3. For each race, each Team Club / National Delegation, through the Head of Delegation or the Team captain, cannot bring more than 2 (two) Protests for each competition. In the event that a Protest is upheld, it shall not be counted towards the maximum number of 2 (two).
4. In RX and Head-to-Head events, a protest may be submitted exclusively by the team that participated in the match and is directly affected by the decision being challenged.
5. The submission of a protest on behalf of, or in the interest of, another team is strictly prohibited.
6. Together with the Protest referred to in paragraph 1, the Head of Delegation or the Team captain must pay the Protest fee, which will be refunded if the Protest is upheld. In the absence of the payment of the fee, contextual to the Protest, the latter cannot be accepted.
7. In Class A), B) and C) events, the Jury shall notify the Head of Delegation or the Team Captain of its decision within twenty (20) minutes following the submission of the claim
8. In order to prove claims, during the examination of the Protest, evidence must be submitted, consisting of the United Rafting official video, official photographs or official footage. If the Local Organizing Committee doesn't provide an official video with the resolution defined in the "Event Requirements Handbook", covering the spot where the claim happened, any personal video is admissible.
9. Personal video materials have to show clearly the infringement or the lack of one, have to unquestionable determine the position of the team on the race course
10. In any case, for the Protests regarding the Downriver any personal video is admissible.
11. After reviewing materials, accepting or not accepting Protest, is the decision of the Jury and this decision is final.

12. If a Protest is accepted, necessary steps to best rectify the situation are determined by the Head Judge. He may grant a re-run if a protest is successful (although they are under no obligation to do so).
13. Protest against a Protest cannot be submitted.
14. The acceptance of a Protest absolutely excludes the cancellation of the race.
15. During the submission and handling of a protest, all parties shall maintain respectful and appropriate conduct. Any verbal abuse, offensive language, or aggressive behaviour directed towards judges or officials shall constitute disciplinary misconduct.
16. A team that elects not to submit a protest but issues public statements or comments that are insulting, defamatory, or denigratory towards United Rafting and/or its appointed officials may be subject to disciplinary proceedings.
17. A team that has duly submitted a protest may issue comments, including public statements, provided that such comments are expressed in respectful and appropriate terms and do not undermine the integrity of the competition or its officials.

Section IV – Particular requirements for Sprint

Art. 29 – Definition

1. The purpose of the sprint is to complete a course in the shortest possible time. The minimum length should be 300 metres, while the maximum length should be 400 metres.
2. The sprint consists of two (2) runs in the Classic Format and of one (1) in the Adventure Format.
3. The start intervals must be between half minute and two minutes between a team and the next one

Art. 30 – Sprint's start and arrival

1. The start and finish procedures are defined in articles 20 and 23.

Art. 31 – Timed sprint's rankings

1. In the Classic format, the result shall be determined by the time taken, expressed in seconds, of the best of the two runs, taking into account any penalties assigned for that run. In the Adventure format, the result shall be determined by the time taken, expressed in seconds, plus any penalties assigned.
2. The penalty points, converted into seconds, are added to the race time.
3. If two or more competing teams finish a race with the same score, they are classified ex-aequo.
4. If two or more competing teams finish the sprint with the same time, the first position for the RX and Head-to-Head is defined by coin toss. If three (3) or more teams are recorded with identical times, the higher placing shall be determined by an additional run, which shall be contested exclusively by the teams sharing the same position.

Section V – Particular requirements for RX

Art. 32 – Definition

1. The purpose of the RX race is to complete, in the shortest possible time, a course between two teams starting simultaneously and with a system of knockout elimination.
2. The RX descent must be carried out in a river section, where both teams find themselves, possibly, in conditions of the same difficulty level and current and where the line of departure allows them to start in the same circumstances.
3. The RX is made up of two phases: the first phase, the so-called *timed sprint*, determines the draw for the second phase, the *knockout phase*. Where the Sprint discipline is organized within the same Event, the results of such Sprint discipline shall be used as the RX Qualification results, unless otherwise specified in the Event Bulletin.
4. On the basis of the results and the number of participants in the timed sprint, only a limited number of teams can access directly to the second stage of the race; all others must complete the first phase of the race to gain access to the second. The Race Director may establish a maximum number of teams that have access to the second stage.
5. The model Knockout System determines the knockout draw on the basis of the timed sprint's results according to the art. 33.

Art. 33 – Knockout phase

1. The formula to determine, the teams that will directly access the knockout phase and those that will have to go through the first knockout phase (“repechage”) is the following:
 - A - B = C**
 - B - C = D**
 - Where:
 - A** = Powers of 2 (2, 4, 8, 16, 32, 64, 128, 356 etc.) From which the number of teams that completed the timed sprint must be deducted
 - B** = number of teams that completed the timed sprint
 - C** = number of teams that automatically go to second stage
 - D** = number of teams competing in the first knockout stage
2. In the knockout phase the teams with the fastest time in the timed sprint will have the priority in choosing their starting position.
3. Late show up or no show up at the starting gate leads to victory of the opposing team.
4. The starting positions of the two teams in the knockout stage must be chosen in the most equal manner possible so that the lines are identical for both teams.

Art. 34 – RX Course

1. The maximum distance of the course must be 300 m.
2. No contact area. In the first part of the course a no contact area is set up. This no contact area begins at the start positions and ends at the orange pole positioned no less than 10 meters from the starting line.
3. An orange pole or a buoy indicates the point from which contact is allowed. The rafts must cross this pole within the time defined by the Head Judge (First Contact Time). The First Contact Time must be presented by the Head Judge during the Heads of Delegations' meeting.

4. In the course upstream and downstream gates are installed according to the art. 35. For the quarter-finals, semi-finals and the finals the course design may be modified.
5. A penalty pair of upstream gates is installed in the last section of the RX course. It should be set no further than 50 meters and no closer than 10 meters from the finish line.

Art. 35 – RX Gates

1. The gates don't touch the water. Gates to be negotiated downriver, in favor of the current, are marked by green stripes. Gates to be negotiated upstream, against the current, are marked by red stripes. The pole must have a maximum height of 2.00 m, a round section with a diameter between 5cm and 7cm, have a sufficient weight not to be moved by the wind and be constructed with a plastic pipe (PVC) or wood.
2. The upstream gates are distributed in pairs along the course and signaled by a single pole. Only one gate in each pair must be negotiated: each team is free to decide which gate to negotiate in each pair.
3. Downstream gates are distributed along the course and signaled by a single pole.
4. The RX course shall include a minimum of one (1) and a maximum of two (2) pairs of upstream gates, excluding the upstream gate pair designated exclusively as a penalty gate.
5. The RX course shall include a minimum of one (1) and a maximum of two (2) downstream gates.
6. Contact with the pole is allowed. The pole shall not be moved intentionally.
7. To consider a regular gate passage, the following conditions must occur:
 - a. all heads of all team members have crossed the gate line together on the correct side, according to the design of the track and appropriate direction of the gate;
 - b. all team members have to be in the raft.
8. During the negotiation of a gate and/or after a regular passage, a team shall be permitted to cross the same gate line again

Art. 36 – RX Penalty

1. A penalty gate is imposed to the team by the Judges:
 - a. when a team invades the other competitor's lane in the no contact area with any part of the boat, or with the body of a member of the team and any other equipment available before point from which it is allowed;
 - b. when the team touches the orange pole, indicating the end of the no contact area, with any part of the boat, or with the body of a member of the team and any other equipment;
 - c. in case of intentional contact;
 - d. when the contact with the gate is intentional.
2. A double penalty gate is imposed to the team by the Judges when a team skips a gate or in case of false start.
3. The number of penalties cannot exceed three (3).
4. In case of one (1) penalty the team has to negotiate one of the penalty gates downstream, without turning around the pole.
5. In case of two (2) penalties the team has to complete two penalty gates: one gate has to be negotiated upstream, turning around the pole, the other has to be negotiated downstream, without turning around the pole.

6. In case of three (3) penalties the team has to complete two penalty gates: both the gates have to be negotiated upstream, turning around the pole.

Art. 37 – Elimination

1. “Elimination” means that the team eliminated shall automatically lose the round and shall be ranked at the bottom of its phase group. Where both teams are eliminated, the team with the best time in the RX Qualification shall advance to the next round.
2. The team is eliminated when:
 - a. a fourth penalty is imposed;
 - b. when the penalty gate is skipped by one or more team members;
 - c. when the passage of the finish line takes place with the raft with an incomplete team;
 - d. the team does not perform or complete the full length of the course.

Art. 38 – Disqualification

1. “Disqualification” means that the team disqualified shall lose all standings from the RX event and shall be ranked as “DSQ”.
2. The team is disqualified and, accordingly, will not be inserted in the final ranking when:
 - a. any member of the team grabs a rope of the other boat;
 - b. any member of the team grabs an athlete of the other boat;
 - c. any member of the team spaces two attached rafts by hand;
 - d. a violent physical contact, that aims to create a risk or damage to the other team, is considered unsportsmanlike by the Judge.

Art. 39 – Start and arrival of the knockout phase

1. The start should occur at a rate of a minimum of 2 and a maximum of 5 minutes between a pair of teams and the next.
2. The start and finish procedures are defined in articles 20, 21 and 23.

Art. 40 – Rankings

1. The final ranking of the race is filled out as follows:
 - a. Final A: the winners of the semi-final race will compete to determine the 1st and 2nd position; the winner will occupy the 1st place, the loser, the 2nd place;
 - b. Final B: the losers of the semi-finals will meet to determine the 3rd and 4th place, the winner will occupy the 3rd place, the loser, the 4th place. If Final B can't be carried out, 3rd and 4th place will be determined by the best time in the RX qualification.
2. The final position of the other teams, for the purposes of the general ranking, is determined by their position against the opposing team eliminated in the same phase and taking into account the best time in the RX qualification. The four teams eliminated in the quarter-finals are classified for the best time in the RX qualification.

Section VI – Particular requirements for the Head-to-Head

Art. 41 – Definition

1. The Head-to-Head (H2H) competition is conducted in a paired, knock-out elimination format, in which two teams race simultaneously along a course marked with designated navigation markers.
2. The format is designed to follow immediately after the Sprint event, with pairings determined according to the results of the Sprint. Each race is intended to test the speed, precision, and tactical skills of competing teams under identical conditions.

Art. 42 – Venue and Course Requirements

1. The venue for the H2H event must provide suitable conditions for pre-race scouting and allow spectators to observe the competition safely and comprehensively.
2. The course shall be designed so that a test raft can navigate its entirety within three (3) minutes when negotiating the required combination of navigation markers, as specified in Rule 3.3.c.iii. Furthermore, the layout of the course, including the positioning of navigation markers and any constrictions, should enable spectators to view the competition from one or more advantageous vantage points, thereby maximizing both safety and engagement.

Art. 43 – Competition Stages and pairing

1. Depending on the total number of teams entered, the H2H may consist of one or two stages. Sprint results shall determine which teams advance directly to Stage 2 and which must first compete in Stage 1. The team with the faster Sprint time shall be granted the privilege of selecting its Start Lane.
2. All relevant information concerning pairings, race order, the number of rounds, and related procedural matters shall be clearly documented in the H2H Race Order Forms.
3. Intervals between successive pairs within the same round shall not exceed three (3) minutes.
4. Teams that arrive late at their designated start position may forfeit their opportunity to compete.
5. Practice runs are mandatory; however, no practice laps or marker negotiations shall be permitted following the final placement of teams.

Art. 44 – Ranking

1. The winners of the semi-final rounds shall compete in the A Final to determine the first and second positions. Conversely, the teams that are defeated in the semi-finals shall contest the B Final to determine the third and fourth positions.
2. Teams eliminated in earlier rounds shall be ranked according to their final times relative to the other teams eliminated in the same round, ensuring an equitable and transparent ranking system.

Art. 45 – Course Design

1. The Start Lane shall be defined as the unobstructed section of the course extending from the starting position to the first constriction—such as a rapid, rock, bend, or other obstacle—where opponents are most likely to come into first physical contact. The Jury and Course Designers are responsible for ensuring, to the greatest extent possible, that both Start Lanes are equivalent in terms of fairness and challenge. The Race Director or Jury may delineate lanes using a clearly marked line when necessary.
2. At A Level Events, Test Teams shall be employed to verify the equality of Start Lanes. Testing may involve timing each lane or, where timing is impractical, having two evenly matched teams race twice, each taking one lane per attempt. Testing shall continue until the Jury confirms that lanes are as equal as humanly possible. On venues with fluctuating water levels, testing shall be conducted as close to race time as feasible. Teams selected for testing must participate voluntarily and cooperate fully to ensure accurate and reliable assessment of lane parity. Selection methods may include local non-competing teams, evenly matched competing teams, random draws, or available teams at the time of testing.

Art. 46 – Navigation Markers and Positioning

1. The H2H course shall include four navigation markers, two positioned near the left shoreline and two near the right. Markers may be buoy markers or hanging markers, and all shall be placed in or near eddy currents to permit reasonable upstream navigation between marker and shoreline. Markers must be of highly visible color and easily identifiable, and may display sponsorship logos provided they do not interfere with visibility or create ambiguity regarding their purpose. All markers must be readily judged by race officials.

Art. 47 – Marker Negotiation

1. Markers may be contacted by any part of the raft, paddle, or team; however, hanging markers may not be intentionally displaced. A marker is considered correctly negotiated when the entire raft and all team heads pass upstream between the marker and the nearby shoreline, with the raft's ultimate trajectory describing a closed loop around the buoy. Incorrect negotiation occurs if a buoy is submerged by the raft or a hanging marker is deliberately displaced. Each team must successfully negotiate at least one marker on the left and one on the right. Teams may choose which markers to attempt and may make multiple attempts. Ramming is permitted unless explicitly prohibited by race officials.

Art. 48 – Marker Design

1. A Level Events: regulation buoys, conical, 150 cm in height with a 100 cm base, inflatable and puncture-resistant, securely tethered.
2. B, C, D Level Events: Non-regulation buoys may be used if regulation markers are unavailable, provided they are sufficiently large, buoyant, and safe.

Art. 49 – Hanging Marker Design

1. A Level Events: Cylindrical, inflatable, puncture-resistant, 150 cm height, 30 cm diameter, securely attached to an overhead line, braced and weighted, base slightly above water.
2. B, C, D Level Events: Non-regulation hanging markers may be used if regulation markers are unavailable, provided they remain visible, safe, and secure.

Art. 50 – Safety

1. Competitors must avoid reckless behavior that could result in injury or substantial damage to the opposing team or equipment. Except for ramming, deliberate striking, holding, or pushing opponents or their equipment is prohibited. Competitors may exit their raft only if the raft is grounded and cannot be freed, or in response to an evident safety hazard. Exiting teams must act safely, avoid interfering with opponents, move the raft only as necessary to resolve the situation, and re-enter the raft immediately once the hazard is mitigated.

Art. 51 – Penalties

1. The following penalties shall apply:
 - a) 10 seconds for crossing into an opponent’s marked Start Lane;
 - b) 50 seconds for a violation of the H2H Safety Rules;
 - c) 50 seconds for correctly negotiating only one marker;
 - d) 100 seconds for failing to correctly negotiate any marker;
2. Disqualification shall be applied in the following cases:
 - a) practicing marker negotiation after final placement, applied only upon a protest supported by video evidence or by direct observation of a Judge;
 - b) taking longer than fifteen (15) minutes to complete the course, subject to adjustment by the Jury after consultation with the H2H course designer.

Section VII – Particular requirements for the Slalom

Art. 52 – Definition

1. The purpose of the race, which is held in two runs, is to travel in the shortest time possible a distance that requires the crossing of gates, in the ascending numerical order of the gates, trying to avoid touching the poles or the skipping of the gates themselves.
2. The slalom race takes place on two runs on the same course.

Art. 53 – The Slalom course

1. The distance for a Slalom race, between the start and finish, should not exceed 300 m.
2. The course must be navigable for its entire length, have natural obstacles and/or artificial that can be always overcome and provide equal conditions for all rafts.
3. The race course shall be designed by one (1) to three (3) Course Designer(s), appointed by the Race Director in consultation with United Rafting.
4. At least one hour before the race, the course must be ready for scouting and approved by the Race Director and the Head Judge.
5. Upon request of any Heads of the Delegations / Team Captains, the Race Director may consider proposals for route changes related to excessive difficulty of the track or safety reasons.
6. The Course Designer(s) must ensure that the path originally conceived is maintained such for the whole duration of the race: they are responsible for the adequate arrangement of the gates and of further equipment and must be ready to perform changes and adjustments proposed by the Race Director.
7. If, during the race, a change in the water level such as to distort the result occurs, the Head Judge must stop the race itself until the water conditions are not returned to normal.
8. If during the race a momentary factor that alters the characteristics of the course occurs, the Head Judge may authorize changes or movements of the gates, that will have to ensure even conditions among competitors.

Art. 54 – Starting Orders

1. The starting order for the Slalom shall be established based on the Sprint results, arranged from the slowest to the fastest time, unless otherwise specified in the Event Bulletin or by the Race Director.
2. The final starting order with the names of the teams and race numbers shall be delivered to the Heads of the Delegations / Team Captains, to the Head Judge and other Race Officials.

Art. 55 – Slalom's start and arrival

1. The start occurs on average at a rate from a minimum of two (2) minutes at a maximum of four (4) minutes between a team and the next one.
2. The start and finish procedures are defined in articles 20 and 23.

Art. 56 – Gates

1. The gates are formed by at least one (1) suspended pole. The downstream, in favor of the current, are indicated by 5 (five) green rings and from 5 (five) white rings, alternating between them; the rings are 20cm high, the poles must always end with the white ring. The upstream, against the current, are marked by 5 (five) red rings and 5 (five) white rings, alternating each other; the rings are 20cm high, the poles must always end with the white ring. The poles must have a maximum height of. 2.00m, a round section with a diameter between 5cm and 7cm, have a sufficient weight not to be moved by the wind and be constructed with a plastic pipe (PVC) or wood.
2. Signs positioned above the gates number them progressively, according to the design of the predisposed race course. They measure cm. 30x30cm. They feature a yellow background with numbers in black, 20cm. High and to 2cm thickness, shown on both sides and crossed by a diagonal red line red 2cm thick on the opposite side to the direction of the correct passage of the gate.
3. The number of gates along the slalom route must be of at least 8 (eight) and maximum of 14 (fourteen), of which a minimum number of 2 (two) and a maximum of 5 (five) must be upstream, evenly distributed on the right and left banks of the left of the river or channel.

Art. 57 – Passing the gates

1. All gates must be overcome in accordance with the numerical sequence and the direction established, as indicated on the signs that indicate the number.
2. All gates must be overcome respecting the correct side of passage.
3. The passage of the gate begins, and the gate is active, when:
 - a. a raft or the body or the head of one or more members of the team or the paddle touches the pole of the gate;
 - b. any competitor's head crosses the gate line.
4. The passage of a gate ends, and gate ceases to be considered active, when:
 - a. the passage of the next door begins, like described in the subparagraph 3;
 - b. crossing the finish line.
5. Even the start and arrival lines are considered, likewise, as the gate line.
6. To consider a regular door passage, the following conditions must occur:
 - a. all heads of all team members have crossed the gate line on the correct direction, according to the design of the track, without touching any pole with the body, with the paddles or with the raft;
 - b. heads of all competitors crossed the line between riverside and pole in proper direction i.e. They must pass, in the case of a gate composed of a single pole, between the pole and the riverside, or, in the case of a gate composed of two poles, between the poles, and in the proper predetermined direction;
 - c. heads of all competitors must pass through the gate while all of the competitors are inside of the boat;
 - d. in the case of the upstream gate, the team is performing continuous advancement through the gate.

Art. 58 – Penalty

1. In a slalom race are the following penalties assigned:
 - a. "0" points-seconds: with correct passage carried out without making mistakes. No team member, with the head, must pass in a way different from the one indicated;

- if this happens, the gate is considered activated, for which, even if the team try again to execute it correctly, a penalty of "50" points-second would occur.
- b. "2" points-seconds in the Classic Format or "5" points-seconds in the Adventure Format: when the passage of the gate is correct, but one or more team members, or any part of their equipment (including the paddle or their raft), touch one or more times the pole of the gate. Repeated touches of the same gate are penalized only once.
 - c. "50" points-seconds:
 - i. when a gate is skipped by the head of one or more team members;
 - ii. when the head of one or more team members crosses the gate line in the wrong direction from that indicated on the map of the course and on the pole;
 - iii. when a competing team skips the passage of the gate. The gate is considered skipped when a team skips crossing a gate, passing to the next one in ascending numerical order;
 - iv. when one or more team members intentionally push the pole to facilitate passage. The action is not considered intentional when the bodies of the team and the boat are already in a position where they would have the ideally passed the gate;
 - v. in the cases referred to in art. 23, paragraph 5, concerning finish procedures;
 - vi. in the cases referred to in art. 59, paragraph 2, concerning obstruction during overtaking.
2. The passage of the raft under the pole of the gate (crossing the gate) without touching cannot entail a penalty.
 3. Subsequent passages in the already overcome gate do not involve penalties if the next gate has been activated, even if the pole was to be touched.
 4. If one or more team members disembark the raft to release the boat from an obstacle (tie) to continue the course, it does not involve penalties.
 5. If one or more team members realize that they are not able to pass an ascending gate with the paddles, it is possible, if the river so permits, that one or more team members descend from the boat, approaching, pulling or pushing the boat up close to the gate; later, before starting to move to the gate line, cross it and proceed with the correct passage, all team members must get on board and go through the gate properly, paddling. If a member or several members of the team are not on board, or if, crossing the gate line, the head of one or more members are not properly within the pole, the team will be penalized with 50 (fifty) points-second; the same penalty will be assigned in the case in which the team is not able to pass the gate, in which case the door itself will be considered skipped.
 6. If, on the contrary, in a valid passage, one or more touches of the pole occur, these will be penalized with 2 (two) points-second once in the Classic Format and with 5 (five) points-second once in the Adventure Format.
 7. The passage of the gates must always occur with the full team (onboard): n. 4 people for R4 and n. 6 people for R6.
 8. 50 points-seconds the maximum possible penalty imposed for each gate.

Art. 59 – Overtaking

1. When more than one Team is simultaneously on the Slalom course, any slower Team shall not obstruct the progress of a faster Team. Where a slower Team is being overtaken, it shall immediately move aside so as to allow the faster Team to pass without hindrance. This obligation shall not apply where the faster Team has failed to make a clear and demonstrable attempt to negotiate all gates correctly.
2. Where a slower Team obstructs the progress of a faster Team, the slower Team's run shall be disqualified. In cases of intentional obstruction, the Team may additionally be sanctioned with a penalty of fifty (50) point-seconds.
3. A faster Team whose progress has been obstructed by a slower Team may request a rerun by submitting a protest to the Jury. The Jury shall grant such rerun only if it is satisfied that the Team made a clear attempt to negotiate all gates correctly.

Art. 60 – Ranking

1. The result is given by the time taken in seconds in the best between the two runs, adding the penalties assigned for respective runs.
2. The penalty points, converted into seconds, are added to the race time.
3. If two (2) or more teams finish a race with the same score, the team with the better result in the Sprint shall be awarded the higher placing.

Section VIII – Particular requirements for the Downriver

Art. 61 – Definition

1. The aim of the Downriver race is to paddle along, in the direction of the current, a pre-established stretch in the shortest possible time, overcoming the technical difficulties that the path provides.

Art. 62 – Distances

1. The path should provide for a minimum length of 3000 meters, maximum of 10,000 meters
2. The path must be navigable in its total length.
3. The course shall be approved by the Race Director, who has the right to choose, taking into account the water level of the moment, an alternative race course.

Art. 63 – Downriver’s start and arrival

1. The start and finish procedures are defined in articles 20, 22 and 23.

Art. 64 – Downriver penalties

1. Intentional blocking is prohibited. This occurs when a team deliberately changes the direction of their raft more than once with the aim of impeding the progress of a faster team. If a team commits intentional blocking, a penalty of ten (10) penalty seconds will be added to their time for each infraction. Conversely, if a team is intentionally blocked by another team, ten (10) penalty seconds will be subtracted from their total time for each instance of blocking.
2. Intentional contact of any prohibited type shall be penalized by ten (10) seconds, to be added to the Team’s total race time, or, in more severe cases, may result in disqualification. Multiple penalties of ten (10) seconds shall be cumulative.
3. Intentional raft-to-raft contact (ramming) is explicitly permitted. Teams must take all reasonable measures to avoid prohibited contact as described above. Any infringement will be sanctioned according to the provisions set forth herein.
4. Rafts must remain within the boundaries of the defined Downriver course. Cutting corners or bypassing course markers, such as buoys, will result in a fifty (50) penalty seconds.
5. The order of arrival ranking is drawn up taking into account the best time achieved.
6. If two (2) or more teams finish the race with the same time, the team with the better result in the Sprint shall be awarded the higher placing.

Section IX – Organization Rules

Art. 70 – Officials (Jury and Judges)

1. All events must be conducted exclusively by Officials operating under the authority and supervision of the Officials Committee, an independent body within the Sport Department, in full compliance with the provisions of the applicable competition regulations.
2. Officials are responsible for ensuring that the event is run fairly and in accordance with these Sport Rules and the specific Official Rules. Their duties include, but are not limited to, monitoring race procedures, enforcing penalties, supervising timing and scoring and resolving disputes within the scope of their authority.
3. For A and B level events the role of an Official is strictly professional and shall be considered incompatible with holding any political position within United Rafting, any technical or managerial role within the event organization, or the office of President or member of the governing body of any National Federation registered at the event. This separation is essential to maintain impartiality, prevent conflicts of interest, and ensure the integrity of the competition.
4. All Officials are expected to act with independence, objectivity and integrity, and any breach of these principles may result in disciplinary measures in accordance with United Rafting regulations.

Art. 71 – Race Director

1. For events classified as Class A), B) and C) the Race Director is appointed by the Local Organizing Committee, with the approval of United Rafting. If necessary United Rafting can appoint the race director.
2. The Race Director must be a United Rafting race official or a person with a complete knowledge of the Sport Rules. The Race Director is responsible for the general management of the competition and for this he/she interacts continuously with the Head Judge and the LOC.
3. In particular, the tasks of the Race Director are:
 - a. to check that the event takes place according to what is indicated by the United Rafting Rules;
 - b. to move, upon justification, the departure times, to change the race course, and, in case of prolonged persistence of the impediment, to cancel the competition;
 - c. to inform the United Rafting Disciplinary bodies of the cases where it is shown the possibility of a sport or disciplinary foul;
 - d. to decide over any other matter arising during the course of the race not ruled by United Rafting Regulations.
4. The decisions of the Race Director have immediate effect.
5. The Race Director must be present on the competition for the entire duration of the event and cannot participate in competitions as a competitor.

Art. 72 – The Local Organizing Committee

1. The Local Organizing Committee (LOC) is the event’s organisational body responsible for running the competition in full compliance with the United Rafting Statutes and Rules and

following the requirements set out in the Event Requirements Handbook. The LOC must be coordinated by a qualified person with overall responsibility for the event.

2. For events classified as Class A) and Class B), the LOC must include the following key positions:
 - Event Manager who is responsible for the overall planning, coordination, management, and delivery of all competitions and training sessions. The Event Manager works closely with the United Rafting Sport Department, technical coordinators, and delegates to ensure the proper execution of the Event, including material management, draws, weigh-ins, and all operational aspects;
 - Safety Manager, referred to art. 73, who in collaboration with the rescue personnel, the Safety Manager holds full responsibility for the safety and security of the event during all competitions and related activities;
 - Transportation Responsible, who oversees the entire transportation system, ensuring smooth transfer of participants from points of arrival to venues, special events, and departure locations.
 - Registrations and Accreditation Responsible, who ensures the validity of all entries and manages the preparation and distribution of registrations and accreditation for athletes, teams, officials, and other participants;
 - Human Resources Responsible, who oversees all volunteers and works closely with the Hospitality Manager. This role includes the appointment and allocation of personnel across all relevant categories within the event;
 - Course Supervisor, coordinates the course construction team and works in direct consultation with the course staff to ensure that the venue meets all technical requirements. The Course Supervisor implements the instructions and decisions of the Course Designer(s) and ensures that the course is safe and suitable for all participants;
 - Athlete & Team Liaison Officer, who serves as the primary point of contact for athletes, teams, and team managers regarding all matters related to the event. Responsibilities include providing official information, coordinating communications between the LOC and participants, and supporting athletes and teams with logistical, technical, and operational inquiries both before and during the event;
 - Accommodation Responsible, who works in collaboration with the Protocol Manager to ensure that rooms are provided in accordance with the established standards and requirements of the Event.
3. The Event Manager must provide United Rafting with the complete list of LOC members for the duration of the event, within the timeframe specified in the Event Requirements Handbook.
4. The roles and responsibilities of the LOC and its members are fully defined in the Event Requirements Handbook, which sets out the operational and organisational duties required to ensure a successful and compliant event.

Art. 73 – The Safety Manager and the rescues service

1. The Safety Manager, in collaboration with the rescue personnel, is entirely responsible for security during the race.
2. The Safety Manager can request the immediate interruption of the race, informing the Race Director and the Head Judge, if he/she considers that the situation is potentially

hazardous, or if the river level reaches a certain level of danger that compromises the safety of the athletes.

3. The Safety Manager must always be present on the competition, for the entire duration of the event and cannot participate in competitions as a competitor, in any class of boats.
4. The Safety Manager may modify the technical clothing and individual safety equipment if necessary.
5. The Organizing Committee must ensure adequate rescue and assistance services in the most difficult and dangerous parts of the course.
1. The Rescue Service has to be guaranteed from the beginning of the free training sessions until the end of all races, it should consist of a large number of experienced and equipped people, with suitable equipment such as throwlines, possible anchored raft, safety kayak, etc. Or other equipment necessary for ensuring maximum safety.
2. The Rescue Service is coordinated by the Safety Manager which must always be present and in contact with the Race Director for the entire duration of the event.
3. Rescue teams may withdraw from the race course and stop their operations only after receiving the notice from the Safety Manager, subject to official approval by the Race Director, that the race ended.

Art. 74 – Timing service

1. In United Rafting Events the timing service must be carried out by the timekeepers of the United Rafting or a similar and equivalent entity/company, recognized and approved by the United Rafting.
2. The times recorded by the timekeepers and validated by the Head Judge are final once the protest time is over.
3. Timekeeping starts the moment that the start signal is given or any part of the raft crosses the start line and finishes when any part of the boat crosses the finish/imaginary line or the system of the time-detection.

Art. 75 – The bulletin

1. For competitions of Class A, B, and C, the Local Organizing Committees (LOCs) shall prepare the official bulletins using the model provided by United Rafting. All bulletins must be produced in compliance with the provisions and requirements set forth in the Event Requirements Handbook.

Art. 76 – Movement and cancellation of a race

1. If 72 hours before the start of an international competition, reasons of force majeure intervene in a way as to prevent the holding of the competition, the Organizing Committee must communicate the impossibility to carry out the competition itself and inform the displacement and / or cancellation of the race to all United Rafting Members registered and the competent bodies.
2. Any shift to a new date, in addition to being previously authorized by the competent United Rafting bodies, must be promptly communicated by the Local Organizing Committee to the United Rafting Sport Department, that shall inform all the United Rafting Members already registered. The latter cannot change their registrations but can communicate other withdrawals, which will not be sanctioned if done within a further deadline together with the notification of the new date.

Art. 77 – Accreditation of Delegations / Teams

1. The accreditation of the delegations/teams takes place in the manner specified in the event bulletin.
2. During the accreditation procedures, each registered delegation/team must be present with a representative; in absence of such representative registrations are confirmed automatically.
3. During accreditation the Head of the Delegation or the Team Captain, by means of appropriate forms, must communicate any withdrawal.

Art. 78 – The Head of Delegation / Team Captain meeting

1. For events involving national delegations, each Delegation shall appoint a Head of Delegation and a Vice-Head of Delegation, both of whom shall be duly accredited for the Event.
2. For events involving club teams, each Club Team shall appoint a Team Captain, who shall be duly accredited for the Event.
3. The Head of Delegation and a Vice-Head of Delegation or the Team Captain are the sole people authorized to act on behalf of the National Federation Member or Team in any official capacity during the course of the Event, in strict compliance with the provisions of these Rules.
4. The Head of Delegation / Team Captain meeting shall be conducted in the manner specified in the Event Bulletin.
5. The meeting shall be chaired by the Event Director, Race Director, Head Judge, and the United Rafting representative. Attendance is limited to those accredited as Head of Delegation, Vice-Head of Delegation, or Team Captains. No other persons may attend, unless specifically invited by United Rafting or the Local Organizing Committee (LOC), and only if duly authorized.
6. In this context, the meeting shall provide all technical information regarding the Event, including the procedures for establishing the starting order of the first race (Sprint). The starting order may be determined by draw, registration order, alphabetical order, or any other method specified in the Event Bulletin.

Art. 79 – Race bibs

1. The Local Organizing Committee (LOC) must provide the bibs with numbering. The bibs must show the numbering clearly on the chest and on the back of the competitor, and, if not on all the members of the team, at least on one competitor sitting in the front, in the direction of motion. This decision will be communicated to the Heads of Delegations.
2. The numbers must be black on a white background, having at least a 15cm character of height and a body of 1.5cm.
3. Each team must appear at the start wearing its bib and must take care of returning it at the end of the race to the LOC in accordance with the instructions given by the same.
4. The LOC must provide the bibs of two different colors (green/red) for RX competitions.
5. The assignment of bibs to competitors shall be prepared by the Race Director through its secretariat.

Annex A – Para-Rafting

1. The Para-Rafting teams must be numerically composed of 4 athletes.
2. The Para-Rafting competition categories are as follows.

RL	<p>RL3 (equivalent to KL3 in para-canoe) Paddlers with trunk function and partial leg function. An RL3 paddler should be able to sit in a forward flexed position. Paddlers use a footboard or the seat to propel the boat. Eligible paddlers typically meet one of the following criteria:</p> <ul style="list-style-type: none"> - limb loss or deficiency: amputation or loss of function equivalent to at least a tarsal-metatarsal amputation of the foot; - loss of muscle strength: in the lower limb(s), equivalent to an incomplete spinal cord injury at s1 or loss of ten muscle grade points on one limb, or fifteen points across two limbs; - impaired range of motion: in the lower limb(s), e.g., joint fusion. <p>RL2 (equivalent to KL2 in para-canoe) Paddlers with limited trunk and leg function. RL2 athletes may require a backrest or additional support to maintain an upright seated position in the boat. Eligible paddlers typically meet one of the following criteria:</p> <ul style="list-style-type: none"> - limb loss or deficiency: Equivalent to double above-leg amputation; - loss of muscle strength: significant muscle weakness in both legs, equivalent to complete spinal cord injury at l3, or incomplete lesion at L1; - impaired range of motion: in lower limbs and trunk. <p>Note: athletes must not be strapped to the raft, except through automatic release systems (with manual backup).</p>
<p>The team must be composed of 2 KL3/KL2 athletes and 2 able-bodied athletes</p>	

OC	<p>OC means “Open category” The eligible Impairments are the following:</p> <ul style="list-style-type: none"> ● Visual Impairment Class B3 (the least severe visual impairment eligible, the highest visual acuity and/or a visual field of less than 20 degrees radius) ● Hearing Impairment (Deaf athletes) ● Intellectual disabilities
<p>The team must be composed of 2 Open category disabled athletes and 2 able-bodied athletes</p>	

3. If fewer than 3 teams are registered in a category, these teams will be combined into a single category.
4. To promote the development of Para-Rafting without creating barriers to entry, status and classification are self-verified by the National Federation of the athlete at the time of event registration in compliance with the documents that may be approved by United Rafting. Verification can follow the procedures used for Para-Canoe athletes. Any classifications recognized in Para-Canoe are automatically valid for Para-Rafting.
5. Para-Rafting competitions fully adhere to the Sport Rules, except in cases where the Race Director may implement specific exemptions if necessary.

Annex B - Point system

Ranking	Classic Format		
	RX	Slalom	Sprint
1° place	100	100	100
2° place	90	90	90
3° place	80	80	80
4° place	75	75	75
5° place	70	70	70
6° place	68	68	68
7° place	66	66	66
8° place	64	64	64
9° place	62	62	62
10° place	60	60	60
11° place	58	58	58
12° place	56	56	56
13° place	54	54	54
14° place	52	52	52
15° place	50	50	50
16° place	48	48	48
17° place	46	46	46
18° place	44	44	44
19° place	42	42	42
20° place	40	40	40
21° place	38	38	38
22° place	36	36	36
23° place	34	34	34
24° place	32	32	32
25° place	30	30	30
26° place	28	28	28
27° place	26	26	26
28° place	24	24	24
29° place	22	22	22
30° place	20	20	20

	Adventure Format		
Ranking	Head to Head	Slalom	Downriver
1° place	100	100	100
2° place	90	90	90
3° place	80	80	80
4° place	75	75	75
5° place	70	70	70
6° place	68	68	68
7° place	66	66	66
8° place	64	64	64
9° place	62	62	62
10° place	60	60	60
11° place	58	58	58
12° place	56	56	56
13° place	54	54	54
14° place	52	52	52
15° place	50	50	50
16° place	48	48	48
17° place	46	46	46
18° place	44	44	44
19° place	42	42	42
20° place	40	40	40
21° place	38	38	38
22° place	36	36	36
23° place	34	34	34
24° place	32	32	32
25° place	30	30	30
26° place	28	28	28
27° place	26	26	26
28° place	24	24	24
29° place	22	22	22
30° place	20	20	20

World Ranking Event Value Factor (EVF)

Each competition is assigned an **Event Value Factor (EVF)** according to its classification:

Class	EVF
A	10
B	5
C	2
D	1.0

Calculation of Final Points

The **final points** awarded to a team or athlete for a competition are calculated as:

$$Final\ Score = Base\ Points \times Event\ Value\ Factor\ (EVF)$$

Annex C - Raft homologation procedure

The aim of these regulations is to regulate the use of raft in United Rafting competitions by ensuring equal treatment of Clubs, United Rafting member National Federations, manufacturers and sponsors in a spirit of fair play and support the rapid and unambiguous identification of players by the race officials and spectators.

Definitions

Manufacturer

A company that designs, produces (directly or through a non-branded licensee) and sells products bearing its own manufacturer trademarks for use in the sports market. Suppliers and other entities that distribute such products are not considered manufacturers.

Manufacturer composite mark

Any sign, device or logo made up of a combination of a manufacturer word mark and a manufacturer design mark in one single representation.

Sponsor trademark

The element of sponsor advertising that is either (a) registered as a trademark at a national or supranational trademark registry within the territory of a UNITED RAFTING member National Federation, or (b) amounts to an indication of sponsorship origin (i.e. *It allows a reasonable person to identify the sponsor as the business responsible for the sponsor advertising*).

United Rafting Manufacturers scheme

The Manufacturers scheme allows rafts manufacturers to register with the United Rafting and provide a prototype of their competition raft to be approved by United Rafting.

All new competition rafts manufactured by registered United Rafting rafts manufacturers must have an United Rafting Manufacturers label permanently fixed into the inside surface of the raft in plain view that cannot be removed or tampered with in any way. These labels can only be purchased by manufacturers registered with the United Rafting Rafts Manufacturers Scheme.

Example Label:

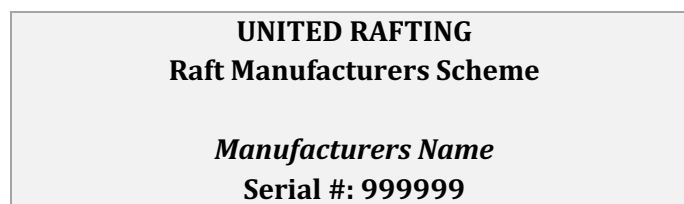

All competition rafts constructed by registered United Rafting Rafts manufacturers must conform to all of the following specifications. Any breaches of these specifications will result in the immediate suspension of that manufacturers license for the period of time decided by United

Rafting Executive Board. During this time, no rafts built by that manufacturer will be permitted United Rafting sanctioned events.

Rafts Specifications

Minimum weight: 30 kg

Maximum weight: 35 kg

Color: orange

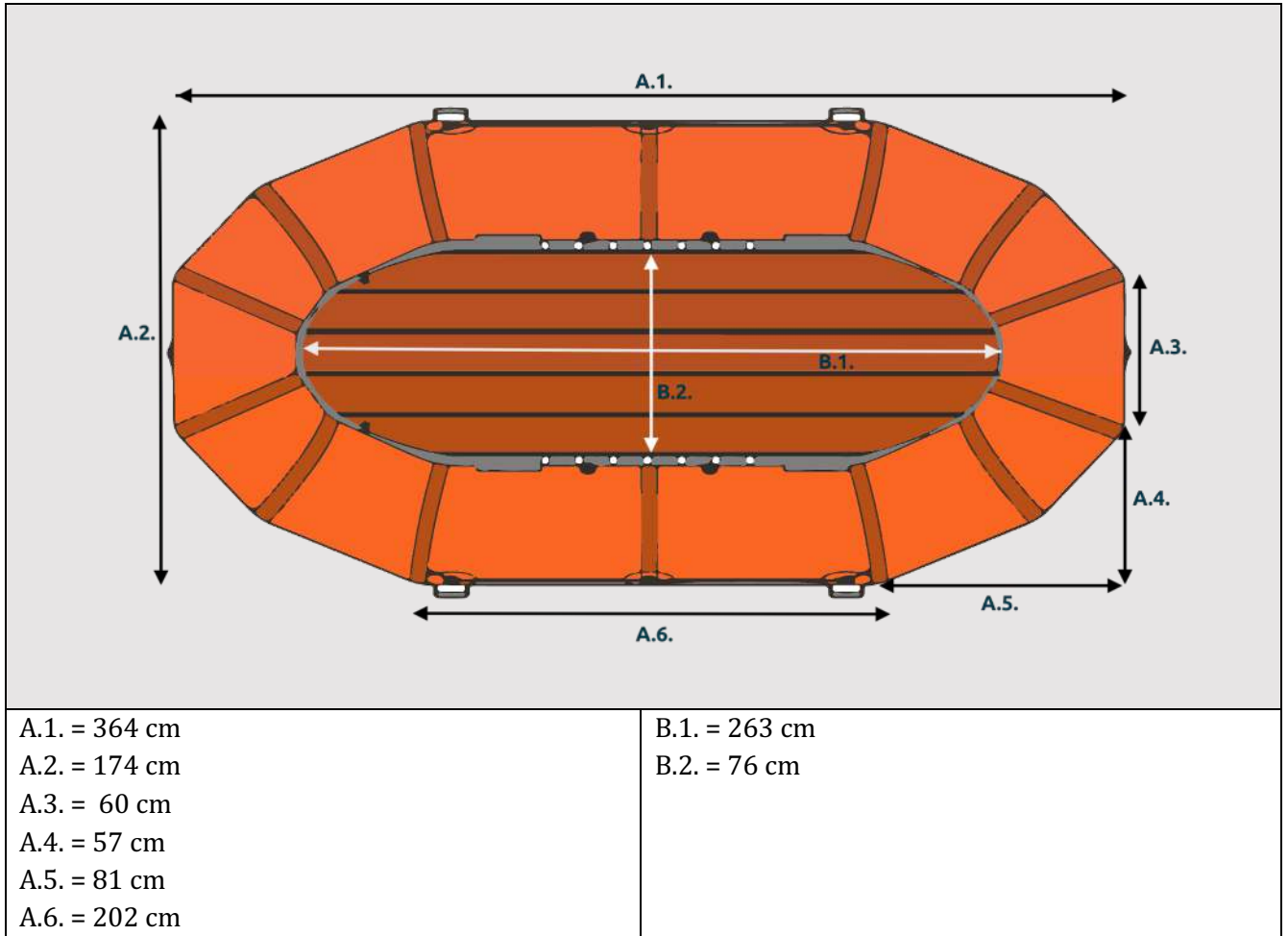

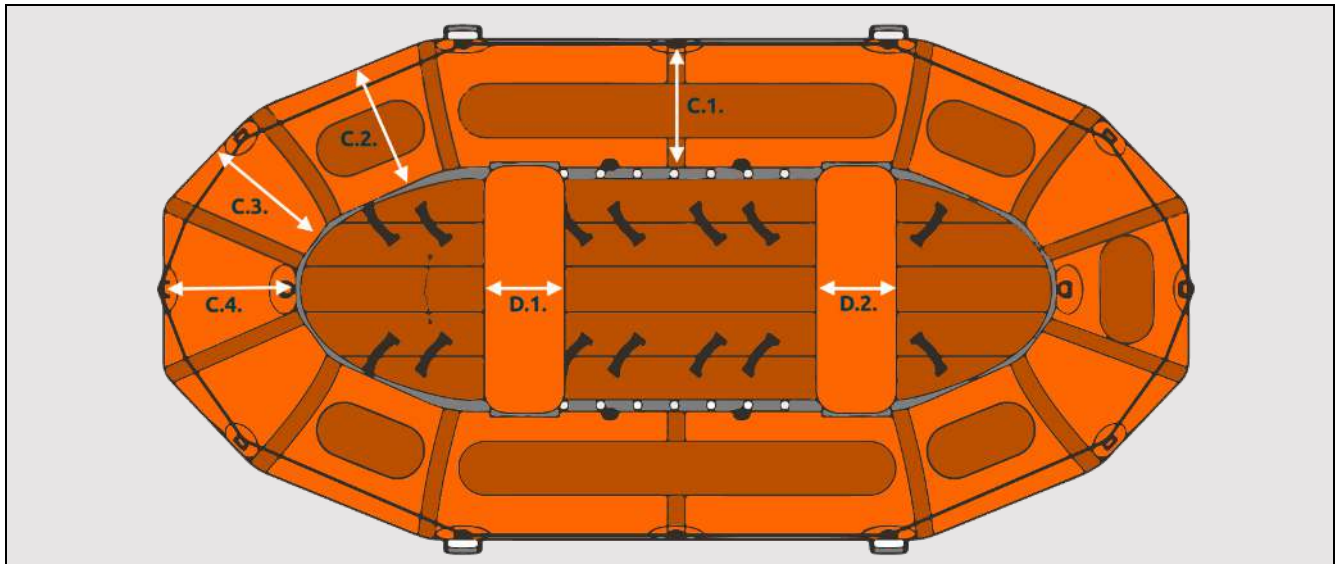

C.1. = 47 cm
 C.2. = 47 cm
 C.3. = 47 cm
 C.4. = 47 cm

D.1. = 28 cm
 D.2. = 28 cm

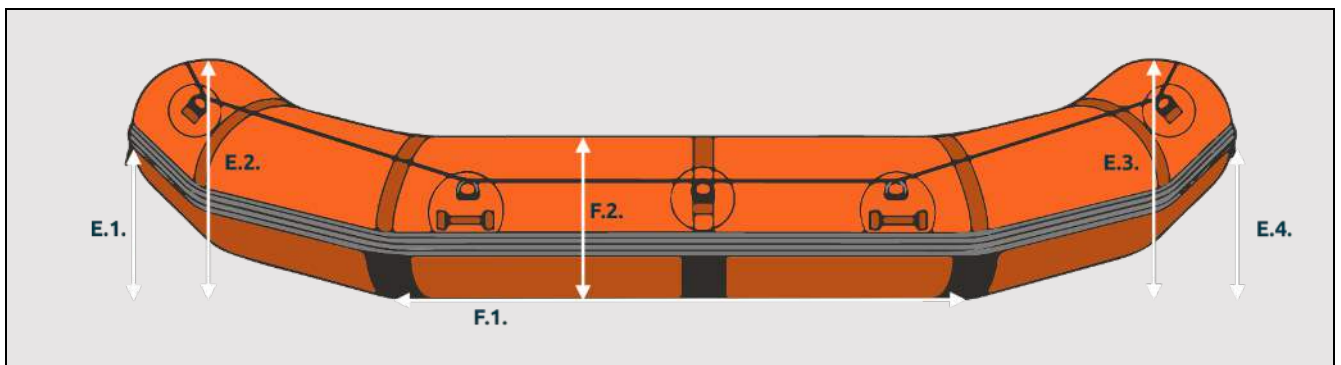

E.1. = 50 cm
 E.2. = 74 cm
 E.3. = 74 cm
 E.4. = 50 cm

F.1. = 200 cm
 F.2. = 47 cm

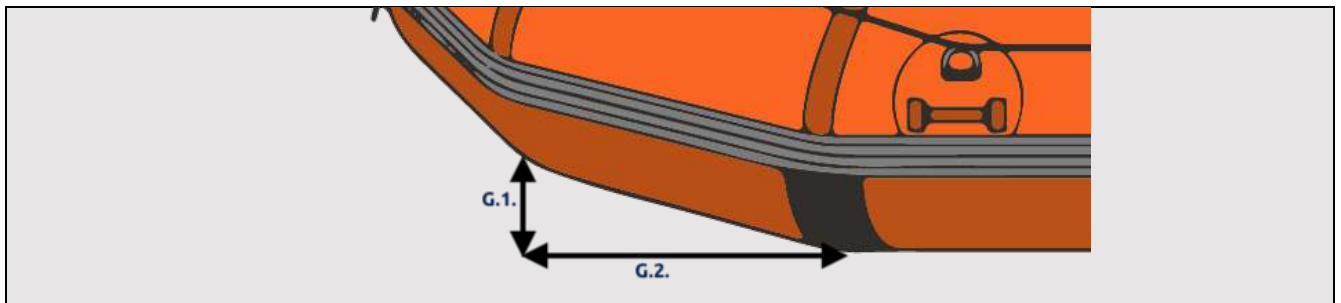

G.1. = 14 cm
 G.2. = 50 cm

Manufacturer composite mark (maximum n. 2 on the external side of the raft) must not touch each other or any other element displayed on raft.

Sponsor trademark identifications (maximum n. 2 on the external side of the raft) must not touch each other or any other element displayed on raft.

How to register

- Send an email to the United Rafting Secretary General with all relevant contact details and your Manufacturer composite mark.
- Send a prototype to the address indicated by United Rafting.

Once United Rafting has approved a prototype, the United Rafting Headquarters shall ratify and sign the necessary documents to complete the approval process. As part of the agreement with United Rafting, the manufacturer shall guarantee the following:

- every raft manufactured shall bear a permanent United Rafting license label, fixed inside the raft in a location where it is minimally exposed to damage;
- the manufacturer shall also recognize a commission fee to United Rafting for each raft sold, as agreed in the licensing terms;
- every competition raft manufactured shall fully comply with the current United Rafting Specifications;
- any raft found to be in breach of these specifications may result in the suspension of the manufacturer's United Rafting status and all rafts produced by that manufacturer shall be banned from all United Rafting events for a period determined by the United Rafting Executive Board.

Annex D – Protest form

The protest may also be submitted in electronic format, using the methods indicated by the Head Judge, or on plain paper, provided it is submitted within the time limits set out in the present Regulations.

Protest

A Protest against a decision of the Judges must be addressed to the Head Judge of the jury in writing and must be accompanied by a fee of 75 euro (or an equal amount in another currency). The Protest must be handed to the Head Judge no later than the time indicated in the Sport Rules.
Protest

Received

Date Time
 _____ _____:

Signature – Head of Delegation / Team Leader
 Judge

Signature – Head

Decision of the Head Judge

The Head Judge has decided to uphold your Protest

The Head Judge has decided to reject your Protest because:

The decision is final.

Signature – Head Judge
